

CMS Manual System	Department of Health & Human Services (DHHS)
Pub 100-04 Medicare Claims Processing	Centers for Medicare & Medicaid Services (CMS)
Transmittal 1264	Date: JUNE 8, 2007
	Change Request 5617

Subject: July 2007 Integrated Outpatient Code Editor (I/OCE) Specifications Version 8.2

I. SUMMARY OF CHANGES: This instruction informs the Fiscal Intermediaries (FIs) and the Fiscal Intermediary Standard System (FISS) of the integration of the non-Outpatient Prospective Payment System (Non-OPPS) OCE into the OPPTS OCE effective July 1, 2007. This integration has resulted in the routing of all institutional outpatient claims (which includes non-OPPS hospital claims) through a single integrated OCE eliminating the need to update, install, and maintain two separate OCE software packages on a quarterly basis. This integration does not change the current logic that is applied to outpatient bill types that already pass through the OPPTS OCE software. It merely expands the software usage to include non-OPPS hospitals. This new software product will be referred to as the Integrated OCE. Claims with dates of service prior to July 1, 2007 should be routed through the non-integrated versions of the OCE software (OPPTS and non-OPPTS OCEs) that coincide with the versions in effect for the date of service on the claim.

New / Revised Material

Effective Date: July 1, 2007

Implementation Date: July 2, 2007

Disclaimer for manual changes only: The revision date and transmittal number apply only to red italicized material. Any other material was previously published and remains unchanged. However, if this revision contains a table of contents, you will receive the new/revised information only, and not the entire table of contents.

II. CHANGES IN MANUAL INSTRUCTIONS: (N/A if manual is not updated)

R=REVISED, N=NEW, D=DELETED

R/N/D	CHAPTER/SECTION/SUBSECTION/TITLE
N/A	

III. FUNDING:

No additional funding will be provided by CMS; contractor activities are to be carried out within their FY 2007 operating budgets.

IV. ATTACHMENTS:

Recurring Update Notification

**Unless otherwise specified, the effective date is the date of service.*

VI. FUNDING

A. *For Fiscal Intermediaries, Carriers, and the Durable Medical Equipment Regional Carrier (DMERC), use only one of the following statements:*

No additional funding will be provided by CMS; contractor activities are to be carried out within their FY 2007 operating budgets.

B. *For Medicare Administrative Contractors (MAC):*

The contractor is hereby advised that this constitutes technical direction as defined in your contract. CMS does not construe this as a change to the Statement of Work (SOW). The contractor is not obligated to incur costs in excess of the amounts specified in your contract unless and until specifically authorized by the contracting officer. If the contractor considers anything provided, as described above, to be outside the current scope of work, the contractor shall withhold performance on the part(s) in question and immediately notify the contracting officer, in writing or by e-mail, and request formal directions regarding continued performance requirements.

2 ATTACHMENTS –

Attachment A-I/OCE Specifications Version 8.2

Attachment B-Final Summary of Data Changes

Attachment A

Integrated Outpatient Code Editor (I/OCE) Specifications Version 8.2

This attachment contains specifications issued for the July I/OCE Version 8.2. All shaded material reflects changes incorporated into the April 2007 OPPS and Non-OPPS versions.

Introduction

This 'integrated' OCE program processes claims for all outpatient institutional providers including hospitals that are subject to the Outpatient Prospective Payment System (OPPS) as well as hospitals that are NOT (Non-OPPS). The Fiscal Intermediary will identify the claim as 'OPPS' or 'Non-OPPS' by passing a flag to the OCE in the claim record, 1=OPPS, 2=Non-OPPS; a blank, zero, or any other value is defaulted to 1.

This version of the OCE processes claims consisting of multiple days of service. The OCE will perform three major functions:

Edit the data to identify errors and return a series of edit flags.

Assign an Ambulatory Payment Classification (APC) number for each service covered under OPSS, and return information to be used as input to a PRICER program.

Assign an Ambulatory Surgical Center (ASC) payment group for services on claims from certain Non-OPSS hospitals.

Each claim will be represented by a collection of data, which will consist of all necessary demographic (header) data, plus all services provided (line items). It will be the user's responsibility to organize all applicable services into a single claim record, and pass them as a unit to the OCE. The OCE only functions on a single claim and does not have any cross claim capabilities. The OCE will accept up to 450 line items per claim. The OCE software is responsible for ordering line items by date of service.

The OCE not only identifies individual errors but also indicates what actions should be taken and the reasons why these actions are necessary. In order to accommodate this functionality, the OCE is structured to return lists of edit numbers. This structure facilitates the linkage between the actions being taken, the reasons for the actions and the information on the claim (e.g., a specific diagnosis) that caused the action.

In general, the OCE performs all functions that require specific reference to HCPCS codes, HCPCS modifiers and ICD-9-CM diagnosis codes. Since these coding systems are complex and annually updated, the centralization of the direct reference to these codes and modifiers in a single program will reduce effort and reduce the chance of inconsistent processing.

The span of time that a claim represents will be controlled by the *From* and *Through* dates that will be part of the input header information. If the claim spans more than one calendar day, the OCE will subdivide the claim into separate days for the purpose of determining discounting and multiple visits on the same calendar day.

Some edits are date driven. For example, Bilateral Procedure is considered an error if a pair of procedures is coded with the same service date, but not if the service dates are different.

Information is passed to the OCE by means of a control block of pointers. Table 1 contains the structure of the OCE control block. The shaded area separates input from return information. Multiple items are assumed to be in contiguous locations.

Pointer Name		UB-04 Form Locator	Number	Size (bytes)	Comment
Dxptr	ICD-9-CM diagnosis codes	70 a-c (Pt's rvdx) 67 (pdx) 67A-Q (sdx)	Up to 16	6	Diagnosis codes apply to whole claim and are not specific to a line item (left justified, blank filled). First listed diagnosis is considered 'patient's reason for visit dx', second diagnosis is considered 'principal dx'
Ndxptr	Count of the number of diagnoses pointed to by Dxptr		1	4	Binary fullword count
Sgptr	Line item entries	42, 44-47	Up to 450	Table 2	
Nsgptr	Count of the number of Line item entries pointed to by Sgptr		1	4	Binary fullword count
Flagptr	Line item action flag Flag set by FI and passed by OCE to Pricer		Up to 450	1	(See Table 7)
Ageptr	Numeric age in years		1	3	0-124
Sexptr	Numeric sex code	11	1	1	0, 1, 2 (unknown, male, female)
Dateptr	From and Through dates (yyyymmdd)	6	2	8	Used to determine multi-day claim
CCptr	Condition codes	18-28	Up to 7	2	Used to identify partial hospitalization and hospice claims
NCCptr	Count of the number of condition codes entered		1	4	Binary fullword count
Billptr	Type of bill	4 (Pos 2-4)	1	3	Used to identify CMHC and claims pending under OPPTS. It is presumed that bill type has been edited for validity by the Standard System before the claim is sent to OCE
NPIProvptr	National provider identifier (NPI)	56	1	13	Pass on to Pricer
OSCARProvptr	OSCAR Medicare provider number	57	1	6	Pass on to Pricer
PstatPtr	Patient status	17	1	2	UB-92 values
OppsPtr	Opps/Non-OPPTS flag		1	1	1=OPPTS, 2=Non-OPPTS (A blank, zero or any other value is defaulted to 1)
OccPtr	Occurrence codes	31-34	Up to 10	2	For FI use
NOccptr	Count of number of occurrence codes		1	4	Binary fullword count
Dxeditptr	Diagnosis edit return buffer		Up to 16	Table 3	Count specified in Ndxptr
Proceditptr	Procedure edit return buffer		Up to 450	Table 3	Count specified in Nsgptr
Meditptr	Modifier edit return buffer		Up to 450	Table 3	Count specified in Nsgptr
Dteditptr	Date edit return buffer		Up to 450	Table 3	Count specified in Nsgptr
Rceditptr	Revenue code edit return buffer		Up to 450	Table 3	Count specified in Nsgptr
APCptr	APC/ASC return buffer		Up to 450	Table 7	Count specified in Nsgptr
Claimptr	Claim return buffer		1	Table 5	
Wkptr	Work area pointer		1	512K	Working storage allocated in user interface
Wklenptr	Actual length of the work area pointed to by Wkptr		1	4	Binary fullword

Table 1: OCE Control block

The input for each line item contains the information described in Table 2.

Field	UB-04 Form Locator	Number	Size (bytes)	Comments
HCPCS procedure code	44	1	5	May be blank
HCPCS modifier	44	5 x 2	10	
Service date	45	1	8	Required for all lines
Revenue code	42	1	4	
Service units	46	1	7	A blank or zero value is defaulted to 1
Charge	47	1	10	Used by PRICER to determine outlier payments

Table 2: Line item input information

There are currently 77 different edits in the OCE. The occurrence of an edit can result in one of six different dispositions.

- Claim Rejection** There are one or more edits present that cause the whole claim to be rejected. A claim rejection means that the provider can correct and resubmit the claim but cannot appeal the claim rejection.
- Claim Denial** There are one or more edits present that cause the whole claim to be denied. A claim denial means that the provider can not resubmit the claim but can appeal the claim denial.
- Claim Return to Provider (RTP)** There are one or more edits present that cause the whole claim to be returned to the provider. A claim returned to the provider means that the provider can resubmit the claim once the problems are corrected.
- Claim Suspension** There are one or more edits present that cause the whole claim to be suspended. A claim suspension means that the claim is not returned to the provider, but is not processed for payment until the FI makes a determination or obtains further information.
- Line Item Rejection** There are one or more edits present that cause one or more individual line items to be rejected. A line item rejection means that the claim can be processed for payment with some line items rejected for payment. The line item can be corrected and resubmitted but cannot be appealed.
- Line Item Denials** There are one or more edits present that cause one or more individual line items to be denied. A line item denial means that the claim can be processed for payment with some line items denied for payment. The line item cannot be resubmitted but can be appealed.

In the initial release of the OCE, many of the edits had a disposition of RTP in order to give providers time to adapt to OPSS. In subsequent releases of the OCE, the disposition of some edits may be changed to other more automatic dispositions such as a line item denial. A single claim can have one or more edits in all six dispositions. Six 0/1 dispositions are contained in the claim return buffer that indicate the presence or absence of edits in each of the six dispositions. In addition, there are six lists of reasons in the claim return buffer that contain the edit numbers that are associated with each disposition. For example, if there were three edits that caused the claim to have a disposition of return to provider, the edit numbers of the three edits would be contained in the claim return to provider reason list. There is more space allocated in the reason lists than is necessary for the current edits in order to allow for future expansion of the number of edits.

In addition to the six individual dispositions, there is also an overall claim disposition, which summarizes the status of the claim.

The following special processing conditions currently apply only to OPSS claims:

- 1) Partial hospitalizations are paid on a per diem basis. There is no HCPCS code that specifies a partial hospitalization related service. Partial hospitalizations are identified by means of condition codes, bill types and HCPCS codes specifying the individual services that constitute a partial hospitalization (See Appendix C). Thus, there are no input line items that directly correspond to the partial hospitalization service. In order to assign the partial hospitalization APC to one of the line items, the payment APC for one of the line items that represent one of the services that comprise partial hospitalization is assigned the partial hospitalization APC.
- 2) Reimbursement for a day of outpatient mental health services in a non-PH program is capped at the amount of the partial hospital per diem. On a non-PHP claim, the OCE totals the payments for all MH services with the same date of service; if the sum of the payments for the individual MH services exceeds the partial hospital per-diem, the OCE assigns a special “Daily Mental Health Service” payment APC to one of the line items that represent MH services. The packaging flag is turned on for all other MH services for that day (See appendix C). The payment rate for the Daily Mental Health Services APC is the same as that for the partial hospitalization APC.
- 3) For outpatients who undergo inpatient-only procedures on an emergency basis and who expire before they can be admitted to the hospital, a specified APC payment is made to the provider as reimbursement for all services on that day. The presence of modifier CA on the inpatient-only procedure line assigns the specified payment APC and associated status and payment indicators to the line. The packaging flag is turned on for all other lines on that day. Payment is only allowed for one procedure with modifier CA. If multiple inpatient-only procedures are submitted with the modifier –CA, the claim is returned to the provider. If modifier CA is submitted with an inpatient-only procedure for a patient who did not expire (patient status code is not 20), the claim is returned to the provider.
- 4) Inpatient-only procedures that are on the separate-procedure list are bypassed when performed incidental to a surgical procedure with Status Indicator T. The line(s) with the inpatient-separate procedure is rejected and the claim is processed according to usual OPSS rules.
- 5) When multiple occurrences of any APC that represents drug administration are assigned in a single day, modifier-59 is required on the code(s) in order to permit payment for multiple units of that APC, up to a specified maximum; additional units above the maximum are packaged. If modifier –59 is not used, only one occurrence of any drug administration APC is allowed and any additional units are packaged (see Appendix I). (v6.0 – v7.3 only)
- 6) The use of a device, or multiple devices, is necessary to the performance of certain outpatient procedures. If any of these procedures is submitted without a code for the required device(s), the claim is returned to the provider. Discontinued procedures (indicated by the presence of modifier 52, 73 or 74 on the line) are not returned for a missing device code.

Conversely, some devices are allowed only with certain procedures, whether or not the specific device is required. If any of these devices is submitted without a code for an allowed procedure, the claim is returned to the provider.

7) Observations may be paid separately if specific criteria are met; otherwise, the observation is packaged into other payable services on the same day. (See Appendix H).

8) Direct admission from a physician's office to observation will be packaged into a payable observation, or into other S or T procedure if present; otherwise, the direct admission is processed as a medical visit (see Appendix H).

9) In some circumstances, in order for Medicare to correctly allocate payment for blood processing and storage, providers are required to submit two lines with different revenue codes for the same service when blood products are billed. One line is required with revenue code 39X and an identical line (same HCPCS, modifier and units) with revenue code 38X (see Appendix J).

10) Certain wound care services may be paid an APC rate or from the Physician Fee Schedule, depending on the circumstances under which the service was provided. The OCE will change the status indicator and remove the APC assignment when these codes are submitted with therapy revenue codes or therapy modifiers.

11) Providers must append modifier 'FB' to procedures that represent implantation of replacement devices that are obtained at no/reduced cost to the provider. If there is an offset payment amount for the procedure, the OCE will reduce the APC rate by the offset amount before determining the highest rate for multiple or terminated procedure discounting. If the modifier is used inappropriately (appended to procedure with SI other than S, T, X or V), the claim is returned to the provider.

12) Certain special HCPCS codes are always packaged when they appear with other services that are subject to APC payment; however, they may be assigned to an APC and paid separately if there is no other APC service on the same day. The OCE will change the SI from Q to N or to the payable SI specified for the code. If there are multiple special codes on a day, only the code assigned to the APC with the highest payment rate will be paid.

13) Submission of the trauma response critical care code requires that the trauma revenue code (068x) and the critical care E&M code (99291) also be present on the claim for the same date of service. Otherwise, the trauma response critical care code will be rejected.

The following special processing condition applies ONLY to Non-OPPS HOPD claims:

1) Bill type of 83x is consistent with the presence of an ASC procedure on the bill and a calculated ASC payment. The Integrated OCE will assign bill type flags to Non-OPPS HOPD claims (opps flag =2) indicating that the bill type should be 83x when there is an ASC procedure code present; and, should not be 83x when there is no ASC procedure present.

All institutional outpatient claims, regardless of facility type, will go through the Integrated Outpatient Code Editor (IOCE); however, not all edits are performed for all sites of service or types of claim. Appendix F (a) contains OCE edits that apply for each bill type under OPSS processing; appendix F (b) contains OCE edits that apply to claims from hospitals not subject to OPSS.

The OPSS PRICER would compute the standard APC payment for a line item as the product of the payment amount corresponding to the assigned payment APC, the discounting factor and the number of units for all line items for which the following is true:

Criteria for applying standard APC payment calculations

APC value is not 00000

Payment indicator has a value of 1 or 5

Packaging flag has a value of zero or 3

Line item denial or rejection flag is zero or the line item action flag is 1

Line item action flag is not 2, 3 or 4

Payment adjustment flag is zero or 1

Payment method flag is zero

If payment adjustments are applicable to a line item (payment adjustment flag is not 0 or 1) then nonstandard calculations are necessary to compute payment for a line item (See Appendix G). The line item action flag is passed as input to the OCE as a means of allowing the FI to override a line item denial or rejection (used by FI to override OCE and have PRICER compute payment ignoring the line item rejection or denial) or allowing the FI to indicate that the line item should be denied or rejected even if there are no OCE edits present. The action flag is also used for handling external line item adjustments. For some sites of service (e.g., hospice) only some services are paid under OPSS.

The line item action flag also impacts the computation of the discounting factor in Appendix D. The Payment Method flag specifies for a particular site of service which of these services are paid under OPSS (See Appendix E). OPSS payment for the claim is computed as the sum of the payments for each line item with the appropriate conversion factor, wage rate adjustment, outlier adjustment, etc. applied. Appendix K summarizes the process of filling in the APC return buffer.

If a claim spans more than one day, the OCE subdivides the claim into separate days for the purpose of determining discounting and multiple visits on the same day. Multiple day claims are determined based on calendar day. The OCE deals with all multiple day claims issues by means of the return information. The Pricer does not need to be aware of the issues associated with multiple day claims. The Pricer simply applies the payment computation as described above and the result is the total OPSS payment for the claim regardless of whether the claim was for a single day or multiple days. If a multiple day claim has a subset of the days with a claim denial, RTP or suspend, the whole claim is denied, RTP or suspended.

For the purpose of determining the version of the OCE to be used, the *From* date on the header information is used.

The edit return buffers consist of a list of the edit numbers that occurred for each diagnosis, procedure, modifier, date or revenue code. For example, if a 75-year-old male had a diagnosis related to pregnancy it would create a conflict between the diagnosis and age and sex. Therefore, the diagnosis edit return buffer for the pregnancy diagnosis would contain the edit numbers 2 and 3. There is more space allocated in the edit return buffers than is necessary for the current edits in order to allow future expansion of the number of edits. The edit return buffers are described in Table 3.

Name	Bytes	Number	Values	Description	Comments
Diagnosis edit return buffer	3	8	0,1-5	Three-digit code specifying the edits that applied to the diagnosis.	There is one 8x3 buffer for each of up to 16 diagnoses.
Procedure edit return buffer	3	30	0,6,8-9,11-21, 28,37-40, 42-45,47, 49-50,52-64, 66 -74, 76, 77	Three-digit code specifying the edits that applied to the procedure.	There is one 30x3 buffer for each of up to 450 line items.
Modifier edit return buffer	3	4	0,22,75	Three-digit code specifying the edits that applied to the modifier.	There is one 4x3 buffer <u>for each of the five modifiers</u> for each of up to 450 line items.
Date edit return buffer	3	4	0,23	Three-digit code specifying the edits that applied to <u>line item</u> dates.	There is one 4x3 buffer for each of up to 450 line items.
Revenue center edit return buffer	3	5	0, 41,48, 65	Three-digit code specifying the edits that applied to revenue centers.	There is one 5x3 buffer for each of up to 450 line items

Table 3: Edit Return Buffers

Each of the return buffers is positionally representative of the source that it contains information for, in the order in which that source was passed to the OCE. For example, the seventh diagnosis return buffer contains information about the seventh diagnosis; the fourth modifier edit buffer contains information about the modifiers in the fourth line item.

There are currently 77 different edits in the OCE, ten of which are inactive for the current version of the program. Each edit is assigned a number. A description of the edits is contained in Table 4.

Edit #	Description	Non-OPPS Hospitals	Disposition
1	Invalid diagnosis code	Y	RTP
2	Diagnosis and age conflict	Y	RTP
3	Diagnosis and sex conflict	Y	RTP
4 ⁴	Medicare secondary payor alert (v1.0-v1.1)		Suspend
5 ⁴	E-diagnosis code cannot be used as principal diagnosis	Y	RTP
6	Invalid procedure code	Y	RTP
7	Procedure and age conflict (Not activated)		RTP
8	Procedure and sex conflict	Y	RTP
9	Non-covered for reasons other than statute	Y (NCL)	Line item denial
10	Service submitted for denial (condition code 21)	Y (new)	Claim denial
11	Service submitted for FI review (condition code 20)	Y (new)	Suspend
12	Questionable covered service	Y	Suspend
13	Separate payment for services is not provided by Medicare (v1.0 – v6.3)		Line item rejection
14	Code indicates a site of service not included in OPPS (v1.0 – v6.3)		Claim RTP
15	Service unit out of range for procedure ¹	Y (new)	RTP
16	Multiple bilateral procedures without modifier 50 (see Appendix A) (v1.0 – v6.2)		RTP
17	Inappropriate specification of bilateral procedure (see Appendix A)	Y (new)	RTP
18	Inpatient procedure ²		Line item denial
19	Mutually exclusive procedure that is not allowed by NCCI even if appropriate modifier is present		Line item rejection
20	Code2 of a code pair that is not allowed by NCCI even if appropriate modifier is present		Line item rejection
21	Medical visit on same day as a type “T” or “S” procedure without modifier 25 (see Appendix B)		Line item rejection
22	Invalid modifier	Y (new)	RTP
23	Invalid date	Y	RTP
24	Date out of OCE range	Y	Suspend
25	Invalid age	Y	RTP
26	Invalid sex	Y	RTP
27	Only incidental services reported ³		Claim rejection
28	Code not recognized by Medicare; alternate code for same service may be available (See Appendix C for logic for edits 29-36, and 63-64)	Y (NRL)	Line item rejection
29	Partial hospitalization service for non-mental health diagnosis		RTP
30	Insufficient services on day of partial hospitalization		Suspend
31	Partial hospitalization on same day as ECT or type T procedure (v1.0 – v6.3)		Suspend
32	Partial hospitalization claim spans 3 or less days with insufficient services on a least one of the days		Suspend
33	Partial hospitalization claim spans more than 3 days with insufficient number of days having mental health services		Suspend
34	Partial hospitalization claim spans more than 3 days with insufficient number of days meeting partial hospitalization criteria		Suspend
35	Only Mental Health education and training services provided		RTP
36	Extensive mental health services provided on day of ECT or type T procedure (v1.0 – v6.3)		Suspend
37	Terminated bilateral procedure or terminated procedure with units greater than one		RTP
38	Inconsistency between implanted device or administered substance and implantation or associated procedure		RTP
39	Mutually exclusive procedure that would be allowed by NCCI if appropriate modifier were present		Line item rejection
40	Code2 of a code pair that would be allowed by NCCI if appropriate modifier were present		Line item rejection

Table 4: Description of edits/claim reasons (Part 1 of 2)

¹ For edit 15, units for *all line items with the same HCPCS on the same day* are added together for the purpose of applying the edit. If the total units exceeds the code's limits, the procedure edit return buffer is set for all line items that have the HCPCS code. If modifier 91 is present on a line item and the HCPCS is on a list of codes that are exempt, the unit edits are not applied.

² Edit 18 causes all other line items on the same day to be line item denied with Edit 49 (see APC/ASC return buffer “Line item denial or reject flag”). No other edits are performed on any lines with Edit 18 or 49.

³ If Edit 27 is triggered, no other edits are performed on the claim.

⁴ Not applicable for patient’s reason for visit diagnosis

Edit	Description	Non-OPPS Hospitals	Disposition
41	Invalid revenue code	Y (new)	RTP
42	Multiple medical visits on same day with same revenue code without condition code G0 (see Appendix B)		RTP
43	Transfusion or blood product exchange without specification of blood product		RTP
44	Observation revenue code on line item with non-observation HCPCS code		RTP
45	Inpatient separate procedures not paid		Line item rejection
46	Partial hospitalization condition code 41 not approved for type of bill	Y* (new)	RTP
47	Service is not separately payable		Line item rejection
48	Revenue center requires HCPCS		RTP
49	Service on same day as inpatient procedure		Line item denial
50	Non-covered based on statutory exclusion	Y (new)	Line item rejection
51	Multiple observations overlap in time (Not activated)		RTP
52	Observation does not meet minimum hours, qualifying diagnoses, and/or 'T' procedure conditions (V3.0-V6.3)		RTP
53	Codes G0378 and G0379 only allowed with bill type 13x or 85x	Y* (new)	Line item rejection
54	Multiple codes for the same service	Y	RTP
55	Non-reportable for site of service		RTP
56	E/M-condition not met and line item date for obs code G0244 is not 12/31 or 1/1 (Active V4.0 – V6.3)		RTP
57	E/M condition not met for separately payable observation and line item date for code G0378 is 1/1		Suspend
58	G0379 only allowed with G0378		RTP
59	Clinical trial requires diagnosis code V707 as other than primary diagnosis		RTP
60	Use of modifier CA with more than one procedure not allowed		RTP
61	Service can only be billed to the DMERC	Y (NRL)	RTP
62	Code not recognized by OPPS ; alternate code for same service may be available		RTP
63	This OT code only billed on partial hospitalization claims (See appendix C)		RTP
64	AT service not payable outside the partial hospitalization program (See appendix C)		Line item rejection
65	Revenue code not recognized by Medicare	Y (new)	Line item rejection
66	Code requires manual pricing		Suspend
67	Service provided prior to FDA approval	Y (new)	Line item rejection
68	Service provided prior to date of National Coverage Determination (NCD) approval	Y (new)	Line item rejection
69	Service provided outside approval period	Y (new)	Line item rejection
70	CA modifier requires patient status code 20		RTP
71	Claim lacks required device code		RTP
72	Service not billable to the Fiscal Intermediary	Y - NRL	RTP
73	Incorrect billing of blood and blood products		RTP
74	Units greater than one for bilateral procedure billed with modifier 50		RTP
75	Incorrect billing of modifier FB		RTP
76	Trauma response critical care code without revenue code 068x and CPT 99291		Line item rejection
77	Claim lacks allowed procedure code		RTP

Table 4: Description of edits/claim reasons (Part 2 of 2)

* Non-OPPS hospital bill types allowed for edit condition

Y = edits apply to Non-OPPS hospital claims (information in parentheses indicates new edits and those similar to previous non-OPPS edits)

The claim return buffer described in Table 5 summarizes the edits that occurred on the claim.

	Bytes	Number	Values	Description
Claim processed flag	1	1	0-3, 9	0 - Claim processed. 1 - Claim could not be processed (edits 23, 24, 46 ^a , or invalid bill type). 2 - Claim could not be processed (claim has no line items). 3 - Claim could not be processed (edit 10 - condition code 21 is present). 9 - Fatal error; OCE can not run - the environment can not be set up as needed; exit immediately.
Num of line items	3	1	nnn	Input value from Nsgptr, or 450, whichever is less.
National provider identifier (NPI)	13	1	aaaaaaaaaaaa	Transferred from input, for Pricer.
OSCAR Medicare provider number	6	1	aaaaaa	Transferred from input, for Pricer.
Overall claim disposition	1	1	0-5	0 - No edits present on claim. 1 - Only edits present are for line item denial or rejection. 2 - Multiple-day claim with one or more days denied or rejected. 3 - Claim denied, rejected, suspended or returned to provider, or single day claim w all line items denied or rejected, w only post payment edits. 4 - Claim denied, rejected, suspended or returned to provider, or single day claim w all line items denied or rejected, w only pre-payment edits. 5 - Claim denied, rejected, suspended or returned to provider, or single day claim w all line items denied or rejected, w both post-payment and pre-payment edits.
Claim rejection disposition	1	1	0-2	0 - Claim not rejected. 1 - There are one or more edits present that cause the claim to be rejected. 2 - There are one or more edits present that cause one or more days of a multiple-day claim to be rejected.
Claim denial disposition	1	1	0-2	0 - Claim not denied. 1 - There are one or more edits present that cause the claim to be denied. 2 - There are one or more edits present that cause one or more days of a multiple-day claim to be denied, or single day claim with all lines denied (edit 18 only).
Claim returned to provider disposition	1	1	0-1	0 - Claim not returned to provider. 1 - There are one or more edits present that cause the claim to be returned to provider.
Claim suspension disposition	1	1	0-1	0 - Claim not suspended. 1 - There are one or more edits present that cause the claim to be suspended.
Line item rejection disposition	1	1	0-1	0 - There are no line item rejections. 1 - There are one or more edits present that cause one or more line items to be rejected.
Line item denial disposition	1	1	0-1	0 - There are no line item denials. 1 - There are one or more edits present that cause one or more line items to be denied.
Claim rejection reasons	3	4	27	Three-digit code specifying edits (See Table 6) that caused the claim to be rejected. There is currently one edit that causes a claim to be rejected.
Claim denial reasons	3	8	10,	Three-digit code specifying edits (see Table 6) that caused the claim to be denied. There is currently one active edit that causes a claim to be denied.
Claim returned to provider reasons	3	30	1-3, 5-6, 8, 14-17, 22-23, 25-26, 29, 35, 37-38, 41-44, 46, 48, 52, 54, 55,56, 58-63, 70-75, 77	Three-digit code specifying edits (see Table 6) that caused the claim to be returned to provider. There are 41 edits that could cause a claim to be returned to provider.
Claim suspension reasons	3	16	4, 11, 12, 24, 30-34, 36, 57, 66	Three-digit code specifying the edits that caused the claim to be suspended (see Table 6). There are 12 edits that could cause a claim to be suspended.
Line item rejection reasons	3	12	13, 19, 20, 21, 28, 39, 40, 45, 47, 50, 53, 64, 65, 67-69, 76	Three-digit code specifying the edits that caused the line item to be rejected (See Table 6). There are 17 edits that could cause a line item to be rejected.
Line item denied reasons	3	6	9, 18, 49	Three-digit code specifying the edits that caused the line item to be denied (see Table 6). There are currently 3 active edits that cause a line item denial.
APC/ASC return buffer flag	1	1	0-1	0 - No services paid under OPPS. APC/ASC return buffer filled in with default values and ASC group number (See App F). 1 - One or more services paid under OPPS. APC/ASC return buffer filled in with APC.
VersionUsed	8	1	yy.vv.rr	Version ID of the version used for processing the claim (e.g., 2.1.0).
Patient Status	2	1		Patient status code - transferred from input.
Opps Flag	1	1	1-2	OPPS/Non-OPPS flag - transferred from input.
Non-OPPS bill type flag	1	1	1-2	Assigned by OCE based on presence/absence of ASC code 1 = Bill type should be 83x 2 = Bill type should not be 83x

Table 5: Claim Return Buffer

^aEdit 46 terminates processing only for those bill types where no other edits are applied (See App. F).

Table 6 summarizes the edit return buffers, claim disposition and claim reasons. Table 6 also summarizes the pre and post payment status of each edit.

Table 6: Relationship between Edits, Disposition and Reasons (part 1 of 2)

Day denial or rejection means that all line items occurring on the day of the day denial or rejection will have the line item denial or rejection indicator (Table 7) set to 1.

Edit Buffers (see Table 3)						Claim Disposition (see Table 5)						Claim Reason (see Table 4)						Edit Occurs on Multi-day Claim						
				Line Item Date	Rev Code	Deny	Reject	RTP	Susp	Line Item Denial	Line Item Reject	Deny	Reject	RTP	Susp	Line Item Denial	Line Item Reject	RTP Whole Claim	Susp Whole Claim	Reject or Deny Claim	Reject Day	Deny or Reject Day *	Pre/ Post Status	
1	1							1						1				Yes						Pre
2	2							1						2				Yes						Pre
3	3							1						3				Yes						Pre
4	4	-	-	-	-	-	-	-	-	-	-	-	-	-	4	-	-	-	-	-	-	-	-	Post
5	5							1						5				Yes						Pre
6		6						1						6				Yes						Pre
7		7						1						7				Yes						Pre
8		8						1						8				Yes						Pre
9		9								1						9								Pre
10		-				1						10								Yes				Pre
11		11							1						11				Yes					Pre
12		12							1						12				Yes					Pre
13		13									1						13							Pre
14		14						1						14				Yes						Pre
15		15						1						15				Yes						Pre
16		16						1						16				Yes						Pre
17		17						1						17				Yes						Pre
18		18				1						18								Yes		Yes		Pre
19		19									1						19							Pre
20		20									1						20							Pre
21		21									1						21							Pre
22			22					1						22				Yes						Pre
23				23				1						23				Yes						Pre
24				-					1						24				Yes					Pre
25								1						25				Yes						Pre
26								1						26				Yes						Pre
27							1						27							Yes				Pre
28		28									1						28							Pre
29								1						29				Yes						Pre
30									1						30				Yes					Pre
31									1						31				Yes					Pre
32									1						32				Yes					Pre
33									1						33				Yes					Pre
34									1						34				Yes					Pre
35								1						35				Yes						Pre
36									1						36				Yes					Pre
37		37						1						37				Yes						Pre
38		38						1						38				Yes						Pre

Table 6: Relationship between Edits, Disposition and Reasons (part 2 of 2)

* Day denial or rejection means that all line items occurring on the day of the day denial or rejection will have the line item denial or rejection indicator (Table 7) set to 1.

Edit Buffers (see Table 3)						Claim Disposition (see Table 5)						Claim Reason (see Table 4)						Edit Occurs on Multi-day Claim						
				Line Item Date	Rev Code	Deny	Reject	RTP	Susp	Line Item Denial	Line Item Reject	Deny	Reject	RTP	Susp	Line Item Denial	Line Item Reject	RTP Whole Claim	Susp Whole Claim	Reject or Deny Claim	Reject Day	Deny or Reject Day *	Pre/ Post Status	
39		39									1						39							Pre
40		40									1						40							Pre
41					41			1						41				Yes						Pre
42		42						1						42				Yes						Pre
43		43						1						43				Yes						Pre
44		44						1						44				Yes						Pre
45		45									1						45							Pre
46								1						46				Yes						Pre
47		47									1						47							Pre
48					48			1						48				Yes						Pre
49		49								1						49							Yes	Pre
50		50									1						50							Pre
51		51						1						51				Yes						Pre
52		52						1						52				Yes						Pre
53		53									1						53							Pre
54		54						1						54				Yes						Pre
55		55						1						55				Yes						Pre
56		56						1						56				Yes						Pre
57		57							1						57				Yes					Pre
58		58						1						58				Yes						Pre
59		59						1						59				Yes						Pre
60		60						1						60				Yes						Pre
61		61						1						61				Yes						Pre
62		62						1						62				Yes						Pre
63		63						1						63				Yes						Pre
64		64									1						64							Pre
65					65						1						65							Pre
66		66							1						66				Yes					Pre
67		67									1						67							Pre
68		68									1						68							Pre
69		69									1						69							Pre
70								1						70				Yes						Pre
71		71						1						71				Yes						Pre
72		72						1						72				Yes						Pre
73		73						1						73				Yes						Pre
74		74						1						74				Yes						Pre
75			75					1						75				Yes						Pre
76		76									1						76							Pre
77		77						1						77				Yes						Pre

Table 7 describes the APC/ASC return buffer. The APC/ASC return buffer contains the APC for each line item along with the relevant information for computing OPPS payment for OPPS hospital claims. Two APC numbers are returned in the APC/ASC fields: HCPCS APC and payment APC. Except when specified otherwise (e.g., partial hospitalization, mental health, observation logic, etc.), the HCPCS APC and the payment APC are always the same. The APC/ASC return buffer contains the information that will be passed to the OPPS PRICER. The APC is only returned for claims from HOPDs that are subject to OPPS, and for the special conditions specified in Appendix F-a.

The APC/ASC return buffer also contains the ASC payment groups for procedures on certain Non-OPPS hospital claims. The ASC group number is returned in the payment APC/ASC field, the HCPCS ASC field is zero-filled.

	Size (bytes)	Values	Description
HCPCS procedure code	5	Alpha	For potential future use by Pricer. Transfer from input
Payment APC/ASC	5	00001-nnnnn	APC used to determine payment. If no APC assigned to line item, the value 00000 is assigned. For partial hospitalization and some inpatient-only procedure claims the payment APC may be different than the APC assigned to the HCPCS code. ASC group for the HCPCS code.
HCPCS APC	5	00001-nnnnn	APC assigned to HCPCS code
Status indicator	2	Alpha [Right justified, blank filled]	A - Services not paid under OPPS B - Non-allowed item or service for OPPS C - Inpatient procedure E - Non-allowed item or service F - Corneal tissue acquisition; certain CRNA services and hepatitis B vaccines G - Drug/Biological Pass-through H - Pass-through device categories, brachytherapy sources, and radiopharmaceutical agents J - New drug or new biological pass-through ¹ K - Non pass-through drugs and biologicals L - Flu/PPV vaccines M - Service not billable to the FI N - Packaged incidental service P - Partial hospitalization service Q - Packaged services subject to separate payment based on criteria S - Significant procedure not subject to multiple procedure discounting T - Significant procedure subject to multiple procedure discounting V - Medical visit to clinic or emergency department W - Invalid HCPCS or Invalid revenue code with blank HCPCS X - Ancillary service Y - Non-implantable DME, Therapeutic Shoes Z - Valid revenue with blank HCPCS and no other SI assigned
Payment indicator	2	Numeric (1- nn) [Right justified, blank filled].	1 - Paid standard hospital OPPS amount (status indicators K, S, T, V, X) 2 - Services not paid under OPPS (status indicator A) 3 - Not paid (Q, M, W, Y, E), or not paid under OPPS (B, C, Z) 4 - Paid at reasonable cost (status indicator F, L) 5 - Paid standard amount for pass-through drug or biological (status indicator G) 6 - Payment based on charge adjusted to cost (status indicator H) 7 - Additional payment for new drug or new biological (status indicator J) 8 - Paid partial hospitalization per diem (status indicator P) 9 - No additional payment, payment included in line items with APCs (status indicator N, or no HCPCS code and certain revenue codes, or HCPCS codes G0176 (activity therapy), G0129 (occupational therapy), or G0177 (patient education and training service))
Discounting formula number	1	1-8	See Appendix D for values
Line item denial or rejection flag	1	0-2	0 - Line item not denied or rejected 1 - Line item denied or rejected (edit return buffer for line item contains a 9, 13, 18, 19, 20, 21, 28, 39, 40, 45, 47, 49, 50, 53, 64, 65, 67, 68, 69, 76) 2 - The line is not denied or rejected, but occurs on a day that has been denied or rejected (not used as of 4/1/02 - v3.0).
Packaging flag	1	0-4	0 - Not packaged 1 - Packaged service (status indicator N, or no HCPCS code and certain revenue codes) 2 - Packaged as part of partial hospital per diem or daily mental health service per diem 3 - Artificial charges for surgical procedure (submitted charges for surgical HCPCS < \$1.01) 4 - Packaged as part of drug administration APC payment (v6.0 - v7.3 only)

Table 7: APC/ASC Return Buffer (Part 1 of 2)

Name	Size (bytes)	Values	Description
Payment adjustment flag	2	0-6 [Right justified, blank filled]	0 - No payment adjustment 1 - Paid standard amount for pass-through drug or biological (status indicator G) 2 - Payment based on charge adjusted to cost (status indicator H) 3 - Additional payment for new drug or new biological applies to APC (status indicator J) ¹ 4 - Deductible not applicable (specific list of HCPCS codes) 5 - Blood/blood product used in blood deductible calculation 6 - Blood processing/storage not subject to blood deductible 7 - Item provided without cost to provider
Payment Method Flag	1	0-4	0 - OPPS pricer determines payment for service 1 - Based on OPPS coverage or billing rules, the service is not paid 2 - Service is not subject to OPPS 3 - Service is not subject to OPPS, and has an OCE line item denial or rejection 4 - Line item is denied or rejected by FI; OCE not applied to line item
Service units	7	1-x	Transferred from input, for Pricer. For the line items assigned APCs 33 or 34, the service units are always assigned a value of one by the OCE even if the input service units were greater than one [Input service units also may be reduced for some Drug administration APCs, based on Appendix I (v6.0 – v7.3 only)]
Charge	10	nnnnnnnnn	Transferred from input, for Pricer; COBOL pic 9(8)v99
Line item action flag	1	0-4	Transferred from input to Pricer, and can impact selection of discounting formula (AppxD). 0 - OCE line item denial or rejection is not ignored 1 - OCE line item denial or rejection is ignored 2 - External line item denial. Line item is denied even if no OCE edits 3 - External line item rejection. Line item is rejected even if no OCE edits 4 - External line item adjustment. Technical charge rules apply.

Table 7: APC/ASC Return Buffer (Part 2 of 2)

¹ Status indicator J was replaced by status indicator G starting in April, 2002 (V3.0)

HCPCS Codes for Reporting Antigen, Vaccine Administration, Splints, and Casts

List of HCPCS codes in the following chart specify vaccine administration, antigen, splints, and casts, which were paid under OPPS for hospitals. In addition in certain situations these services when provided by HHA's not under the Home Health PPS, and to hospice patients for the treatment of a non-terminal illness are paid under OPPS.

Category	Code
Antigen	95144, 95145, 95146, 95147, 95148, 95149, 95165, 95170, 95180, 95199
Vaccine Administration	90471, 90472, G0008, G0009
Splints	29105, 29125, 29126, 29130, 29131, 29505, 29515
Casts	29000, 29010, 29015, 29020, 29025, 29035, 29040, 29044, 29046, 29049, 29055, 29058, 29065, 29075, 29085, 29086, 29305, 29325, 29345, 29355, 29358, 29365, 29405, 29425, 29435, 29440, 29445, 29450, 29700, 29705, 29710, 29715, 29720, 29730, 29740, 29750, 29799

Correct Coding Initiative (CCI) Edits

The OPPS OCE will generate CCI edits for OPPS hospitals. All CCI edits are incorporated in the I/OCE with the exception of anesthesiology, E&M, mental health, and certain drug administration code pairs. Modifiers and coding pairs in the OCE may differ from those in the NCCI because of differences between facility and professional services.

Effective January 1, 2006 these CCI edits will also apply to ALL services billed, under bill types 22X, 23X, 34X, 74X, and 75X, by the following providers: Skilled Nursing Facilities (SNF's), Outpatient Physical Therapy and Speech-Language Pathology Providers (OPT's), CORF's, and Home Health Agencies (HHA's).

The CCI edits are applicable to claims submitted on behalf of the same beneficiary, provided by the same provider, and on the same date of service. The edits address two major types of coding situations. One type, referred to as the comprehensive/component edits, are those edits to code combinations where one of the codes is a component of the more comprehensive code. In this instance only the comprehensive code is paid. The other type, referred to as the mutually exclusive edits, are those edits applied to code combinations where one of the codes is considered to be either impossible or improbable to be performed with the other code. Other unacceptable code combinations are also included. One such code combination consists of one code that represents a service 'with' something and the other is 'without' the something. The edit is set to pay the lesser-priced service.

Version 13.2 of CCI edits is included in the July OCE.

NOTE: The CCI edits in the OCE are always one quarter behind the Carrier CCI edits.

See Appendix Fa and Fb "OCE Edits Applied by Bill Type" for bill types that the I/OCE will subject to these and other OCE edits.

Appendix A (OPPS & Non-OPPS) Bilateral Procedure Logic

There is a list of codes that are exclusively bilateral if a modifier of 50 is present*. The following edits apply to these bilateral procedures*.

Condition	Action	Edit
The same code which can be performed bilaterally occurs two or more times on the same date of service, all codes <i>without</i> a 50 modifier	Return claim to provider	16
The same code which can be performed bilaterally occurs two or more times (based on units and/or lines) on the same date of service, all or some codes <i>with</i> a 50 modifier	Return claim to provider	17

There is a list of codes that are considered inherently bilateral even if a modifier of 50 is not present. The following edit applies to these bilateral procedures**.

Condition	Action	Edit
The same bilateral code occurs two or more times (based on units and/or lines) on the same date of service	Return claim to provider	17

There are two lists of codes, one is considered conditionally bilateral and the other independently bilateral if a modifier 50 is present. The following edit applies to these bilateral procedures (effective 10/1/06). [OPPS claims only]

Condition	Action	Edit
The bilateral code occurs with modifier 50 and more than one unit of service on the same line	Return claim to provider	74

Note: For ER and observation claims, all services on the claim are treated like any normal claim, including multiple day processing.

*Note: The “exclusively bilateral” list was eliminated, effective 10/1/05 (v6.3); edits 16 and 17 will not be triggered by the presence/absence of modifier 50 on certain bilateral codes for dates of service on or after 10/1/05.

** Exception: For codes with SI of V that are also on the Inherent Bilateral list, condition code ‘G0’ will take precedence over the bilateral edit; these claims will not receive edit 17 nor be returned to provider.

Appendix B (OPPS Only)

Rules for Medical and Procedure Visits on the Same Day and for Multiple Medical Visits on Same Day

Under some circumstances, medical visits on the same date as a procedure will result in additional payments. A modifier of **25** with an Evaluation and Management (E&M) code, status indicator V, is used to report a medical visit that takes place on the same date that a procedure with status indicator S or T is performed, but that is significant and separately identifiable from the procedure. However, if any E&M code that occurs on a day with a type “T” or “S” procedure does not have a modifier of 25, then edit 21 will apply and there will be a line item rejection.

If there are multiple E&M codes on the same day, on the same claim the rules associated with multiple medical visits are shown in the following table.

E&M Code	Revenue Center	Condition Code	Action	Edit
2 or more	Revenue center is different for each E&M code, and all E&M codes have units equal to 1.	Not G0	Assign medical APC to each line item with E&M code	-
2 or more	Two or more E&M codes have the same revenue center OR One or more E&M codes with units greater than one had same revenue center	Not G0	Assign medical APC to each line item with E&M code and Return Claim to Provider	42
2 or more	Two or more E&M codes have the same revenue center OR one or more E&M codes with units greater than one had same revenue center	G0*	Assign medical APC to each line item with E&M code	-

The condition code G0 specifies that multiple medical visits occurred on the same day with the same revenue center, and that these visits were distinct and constituted independent visits (e.g., two visits to the ER for chest pain).

* For codes with SI of V that are also on the Inherent Bilateral list, condition code ‘G0’ will take precedence over the bilateral edit to allow multiple medical visits on the same day.

Appendix C (OPPS Only) Partial Hospitalization Logic

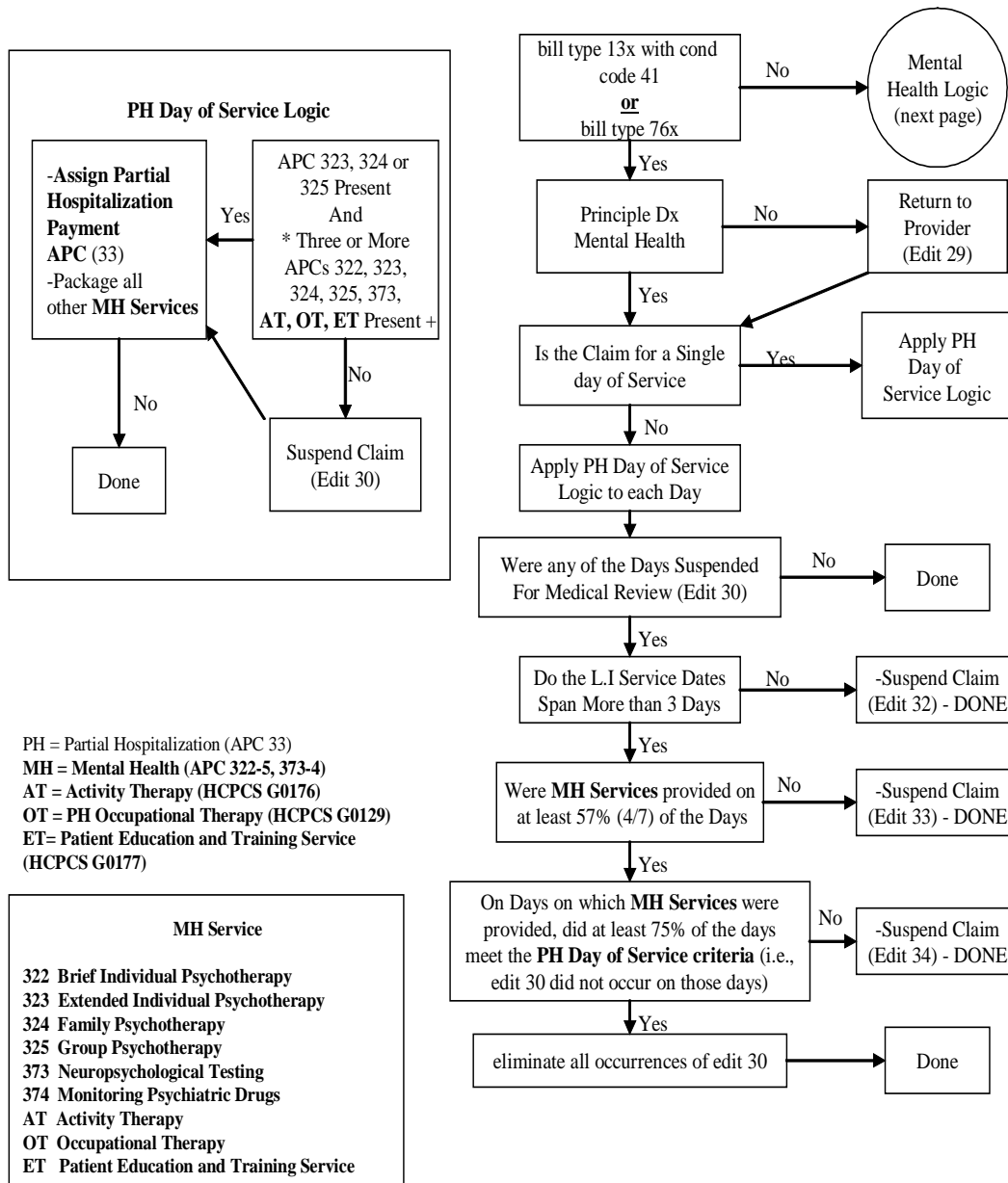

+ Multiple occurrences of APC 322, 323, 324, 325, and 373; AT and ET are treated as separate units in determining whether 3 or more MH services are present. However, multiple occurrences of OT are treated as a single service.

*To avoid confusion over this programming language, the OCE will continue to verify that the claim has, at a minimum, a total of 3 partial hospitalization HCPCS codes for each day of service, one of which must be a psychotherapy HCPCS that groups to APC 323, 324 or 325.

Assign Partial Hospitalization Payment APC

For any day that has a MH Service, the first listed line item from the following hierarchical list (APC 323, 324, 325, 322, 373, 374, AT, OT, ET) is assigned a payment APC of 33, a status indicator of P, a payment indicator of 8, a discounting factor of 1, a line item denial or rejection indicator of 0, a packaging flag of 0, a payment adjustment flag of 0, and a service unit of 1

For all other line items with a **mental health service** (APC 322, 323, 324, 325, 373, 374, AT, OT, ET) the packaging flag is set to 2.

Appendix C (cont'd) Mental Health Logic

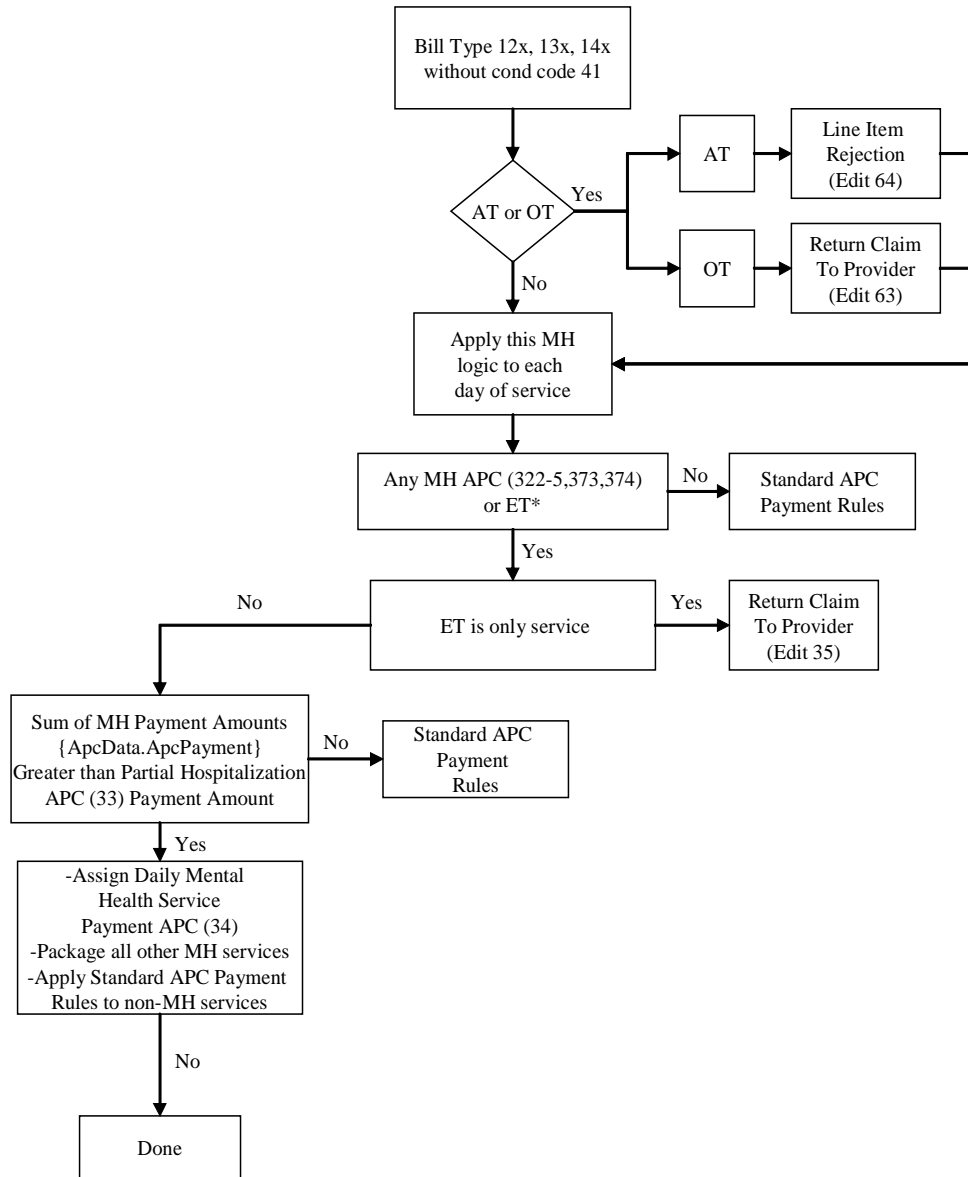

Assign Daily Mental Health Service Payment APC

The first listed line item with HCPCS APC/service from the list of MH APCs/services (322-5, 373, 374) is assigned a payment APC of 34, a status indicator of P, a payment indicator of 8, a discounting factor of 1, a line item denial or rejection indicator of 0, a packaging flag of 0, a payment adjustment flag of 0 and a service unit of 1.

For all other line items with a **mental health service** (APC 322-5, 373, 374, ET) the packaging flag is set to 2.

*NOTE: The use of code G0177 (ET) is allowed on MH claims that are not billed as Partial Hospitalization

Appendix D

Computation of Discounting Fraction (OPPS Only)

Type “T” Multiple and Terminated Procedure Discounting:

Line items with a status indicator of “T” are subject to multiple-procedure discounting *unless modifiers 76, 77, 78 and/or 79 are present*. The “T” line item with the highest payment amount will *not* be multiple procedure discounted, and all other “T” line items will be multiple procedure discounted. All line items that do not have a status indicator of “T” will be ignored in determining the multiple procedure discount. A modifier of 52 or 73 indicates that a procedure was terminated prior to anesthesia. A terminated type “T” procedure will also be discounted although not necessarily at the same level as the discount for multiple type “T” procedures.

Terminated bilateral procedures or terminated procedures with units greater than one should not occur, and have the discounting factor set so as to result in the equivalent of a single procedure. Claims submitted with terminated bilateral procedures or terminated procedure with units greater than one are returned to the provider (edit 37).

Bilateral procedures are identified from the “bilateral” field in the physician fee schedule. Bilateral procedures have the following values in the “bilateral” field:

1. Conditional bilateral (i.e. procedure is considered bilateral if the modifier 50 is present)
2. Inherent bilateral (i.e. procedure in and of itself is bilateral)
3. Independent bilateral (i.e., procedure is considered bilateral if the modifier 50 is present, but full payment should be made for each procedure (e.g., certain radiological procedures))

Inherent bilateral procedures will be treated as non-bilateral procedures since the bilateralism of the procedure is encompassed in the code. For bilateral procedures the type “T” procedure discounting rules will take precedence over the discounting specified in the physician fee schedule.

All line items for which the line item denial or reject indicator is 1 and the line item action flag is zero, or the line item action flag is 2, 3 or 4, will be ignored in determining the discount; packaged line items, (the packaging flag is not zero or 3), will also be ignored in determining the discount. The discounting process will utilize an APC payment amount file. The discounting factor for bilateral procedures is the same as the discounting factor for multiple type “T” procedures.

Non-Type T Procedure Discounting:

Line items with SI other than “T” are subject to bilateral procedure discounting with modifier 50, if identified in the physician fee schedule as Conditional bilateral; and to terminated procedure discounting when modifier 52 or 73 is present.

There are eight different discount formulas that can be applied to a line item.

1. 1.0
2. $(1.0 + D(U-1))/U$
3. T/U
4. $(1 + D)/U$
5. D
6. TD/U
7. $D(1 + D)/U$
8. 2.0

Where

D = discounting fraction (currently 0.5)

U = number of units

T = terminated procedure discount (currently 0.5)

The discount formula that applies is summarized in the following table.

Discounting Formula Number						
			Type "T" Procedure		Non Type "T" Procedure	
Payment Amount	Modifier 52 or 73	Modifier 50	Conditional or Independent Bilateral	Inherent or Non Bilateral	Conditional or Independent Bilateral	Inherent or Non Bilateral
Highest	No	No	2	2	1	1
Highest	Yes	No	3	3	3	3
Highest	No	Yes	4	2	4/8*	1
Highest	Yes	Yes	3	3	3	3
Not Highest	No	No	5	5	1	1
Not Highest	Yes	No	6	6	3	3
Not Highest	No	Yes	7	5	4/8*	1
Not Highest	Yes	Yes	6	6	3	3

For the purpose of determining which APC has the highest payment amount, the terminated procedure discount (T) and any applicable offset, will be applied prior to selecting the type T procedure with the highest payment amount. If both offset and terminated procedure discount apply, the offset will be applied first, before the terminated procedure discount.

*If not terminated, non-type T Conditional bilateral procedures with modifier 50 will be assigned discount formula #4; non-type T Independent bilateral procedures with modifier 50 will be assigned to formula #8.

Appendix E(a) [OPPS flag =1] Logic for Assigning Payment Method Flag Values

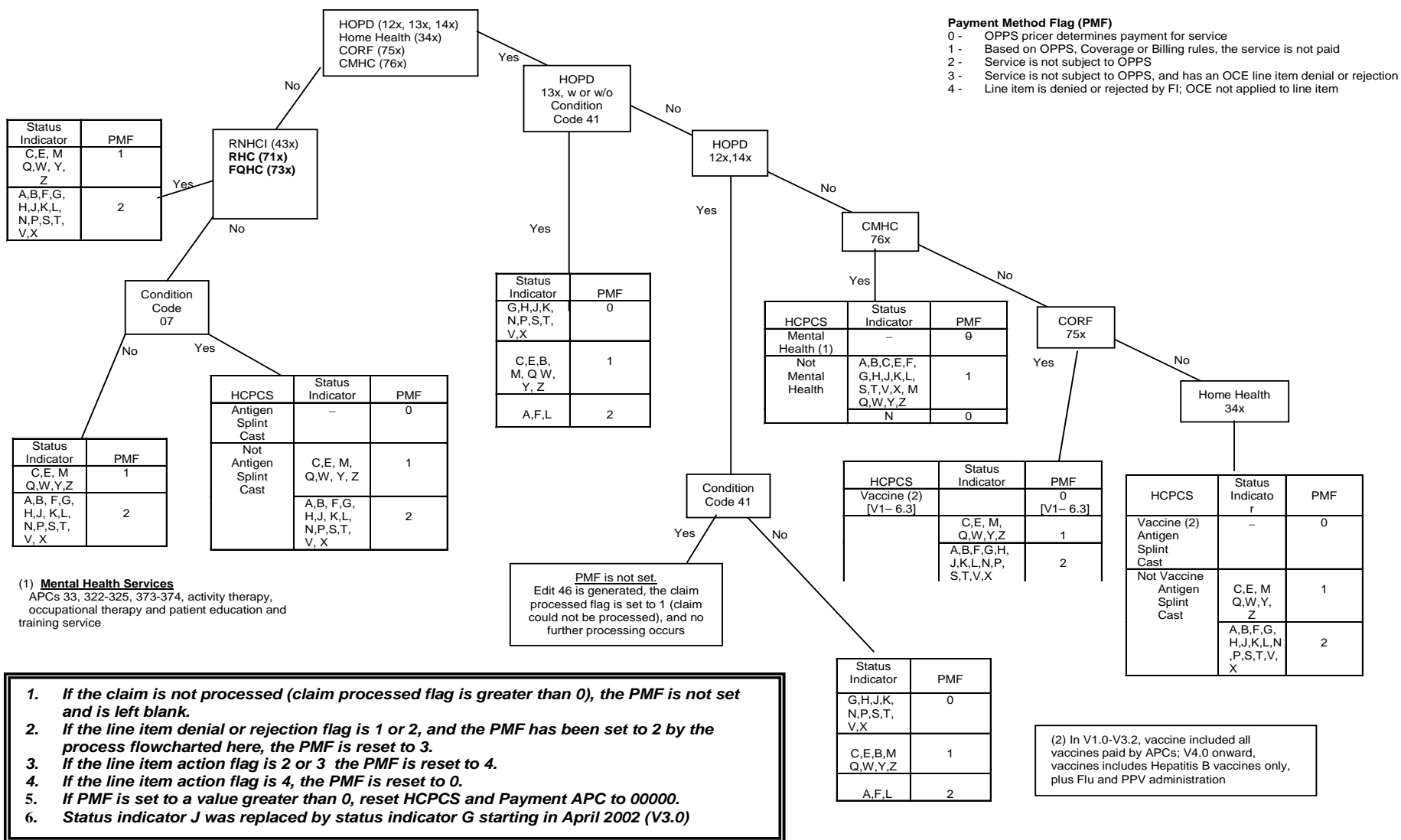

Appendix E(b) [OPPS flag = 2] Logic for Assigning Non-OPPS Hospital Payment Method Flag Values

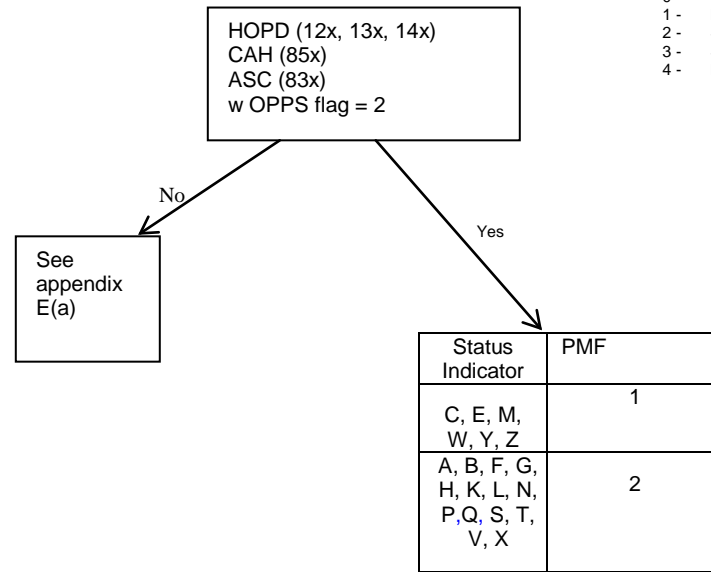

Payment Method Flag (PMF)

- 0 - OPPS pricer determines payment for service
- 1 - Based on OPPS, Coverage or Billing rules, the service is not paid
- 2 - Service is not subject to OPPS
- 3 - Service is not subject to OPPS, and has an OCE line item denial or rejection
- 4 - Line item is denied or rejected by FI; OCE not applied to line item

1. *If the claim is not processed (claim processed flag is greater than 0), the PMF is not set and is left blank.*
2. *If the line item denial or rejection flag is 1 or 2, and the PMF has been set to 2 by the process flowcharted here, the PMF is reset to 3.*
3. *If the line item action flag is 2 or 3 the PMF is reset to 4.*
4. *If the line item action flag is 4, the PMF is reset to 0.*

Appendix F(a) - OCE Edits Applied by Bill Type [OPPS flag =1]

FLOW CHART CELL (*)	Provider/Bill Types	Proc [7, 8, 9, 11, 12, 50, 53 ^e , 54, 59, 69] Proc & Modifier [18,38,43,45,47,49,71,73,75,77] Non Medicare [28] Non OPPS [62] OPPS site of svc [14] HCPC [6,13] Dx [1-5]																						Modifier [16,17, 22,37, 74] HCPC Req'd [48 ^g] CCI [19,20,39,40] ^a Line Item Date [15] Rev Code [23] Rev Code [41,65] Age, Sex [25,26] Partial Hosp [29-34] APC [21,27,42] APC [29-34] Bill Type [46] APC buffer completed [60], Manual Price [66, 70], FDA/NCD [67, 68], Trauma[76] Obs Logic [52,56,57], DirAdm [58], Spec Inpt [60], Manual Price [66, 70], FDA/NCD [67, 68], Trauma[76] DME (61); Not FI (72) Opps Proc (55)																					
		1	2	3	4	5	6	7	8	9	10	11	12	13	14	15	16	17	18	19	20	21	22																						
1	12X or 14X w cond code 41	No	No	No	No	No	No	No	No	No	No	No	No	No	No	No	No	No	No	No	No	No																							
2	12X or 14X w.o cond code 41	Yes	Yes	Yes	Yes	Yes	Yes	Yes	Yes	Yes	Yes	Yes	Yes	Yes	Yes	Yes	Yes	Yes	Yes	Yes	Yes	Yes																							
3	13X w condition code 41	Yes	Yes	Yes	Yes	Yes	Yes	Yes	Yes	Yes	Yes	Yes	Yes	Yes	Yes	Yes	Yes	Yes	Yes	Yes	Yes	Yes																							
4	13X w.o condition code 41	Yes	Yes	Yes	Yes	Yes	Yes	Yes	Yes	Yes	Yes	Yes	Yes	Yes	Yes	Yes	Yes	Yes	Yes	Yes	Yes	Yes																							
5	76X (CMHC)	Yes	Yes	Yes	No	No	Yes	Yes	No	No	Yes	Yes	Yes	Yes	Yes	Yes	Yes	No	No	Yes	No	Yes																							
6	34X ^h (HHA) w Vaccine ^e , Antigen, Splint or Cast	Yes	Yes	Yes	No	Yes	Yes	No	No	Yes	Yes	No	Yes	Yes	Yes	No	No	No	No	Yes	No	Yes																							
7	34X ^h (HHA) w.o Vaccine ^e , Antigen, Splint or Cast	Yes	Yes	Yes	No	No	No	No	No	Yes	No	No	Yes	Yes	Yes	No	No	No	No	No	No	Yes																							
8	75X(CORF) w Vac(PPS)[v1-6.3]	Yes	Yes	Yes	No	Yes	Yes	Yes	No	Yes	Yes	No	Yes	Yes	Yes	No	No	No	No	Yes	No	Yes																							
9	43X (RNHCI)	No	No	No	No	No	No	No	No	No	No	No	Yes	Yes	Yes	No	No	No	Yes	No	No	Yes																							
10	71X (RHC), 73X (FQHC)	Yes	No	No	No	No	No	No	No	No	No	No	Yes	No	Yes	No	No	No	No	No	No	Yes																							
11	Any bill type except 12x,13x, 14x, 34x, 43x, 71x, 73x, 76x, w CC 07, w Antigen, Splint or Cast	Yes ^f	Yes ^f	Yes	No	Yes	Yes	No	No	No	No	Yes	Yes	Yes	Yes	No	No	No	No	Yes	No	Yes																							
12	75X ^h (CORFs)	Yes	Yes	Yes	No	No	No	Yes	No	Yes	Yes	Yes	Yes	Yes	Yes	No	No	No	No	No	No	Yes																							
13	22X ^h , 23X ^h (SNF), 24X ^g	Yes	Yes	Yes	No	Yes ^j	No	No	No	Yes	No	Yes	Yes	Yes	Yes	No	No	No	No	No	No	Yes																							
14	32X, 33X (HHA)	Yes ^f	Yes ^f	No	No	No	No	No	No	No	No	No	Yes	Yes	Yes	No	No	No	No	No	No	Yes																							
15	72X (ESRD)	Yes	Yes	No	No	No	No	No	No	No	No	No	Yes	Yes	Yes	No	No	No	No	No	No	Yes																							
16	74X ^h (OPTs)	Yes	Yes	Yes	No	No	No	Yes	No	Yes	No	No	Yes	Yes	Yes	No	No	No	No	No	No	Yes																							
17	81x (Hospice), 82x	Yes	Yes	No	No	No	No	No	No	No	No	No	Yes	Yes	Yes	No	No	No	No	No	No	Yes																							

(*) FLOW CHART CELLS ARE IN HIERARCHICAL ORDER

Yes = edits apply, No = edits do not apply

Edit 10, and Edits 23 and 24 for From/Through dates, are not dependent on AppxF

^a if edit 23 is not applied, the lowest service (or From) date is substituted for invalid dates, and processing continues.

^b Bypass edit 22 if Revenue code is 540 ^c Edits 53 not applicable for bill type 13x

^d Bypass edit 48 if Revenue code is 100x, 210x, 310x,0905, 0906, 0907; 0500, 0509, 0583, 0660-0663, 0669, 0931, 0932; 0521, 0522, 0524, 0525, 0527, 0528

^eIn V1.0 to V3.2,"vaccines" included all vaccines paid by APCs; from V4.0 onward, "vaccines" includes Hepatitis B vaccines only, plus Flu and PPV administration

^fBypass diagnosis edits (1-5) for bill types 32X and 33X (HHA) if from date is <10/1/xx and Through date is >= 10/1/xx

^g Delete TOB 24X effective 10/1/05

^hApply CCI edits to TOB 22x, 23x, 34x, 74x and 75x, effective 1/1/06

^j Apply edit 28, effective 10/1/05

Appendix F(a) Flow Chart [OPPS flag = 1]

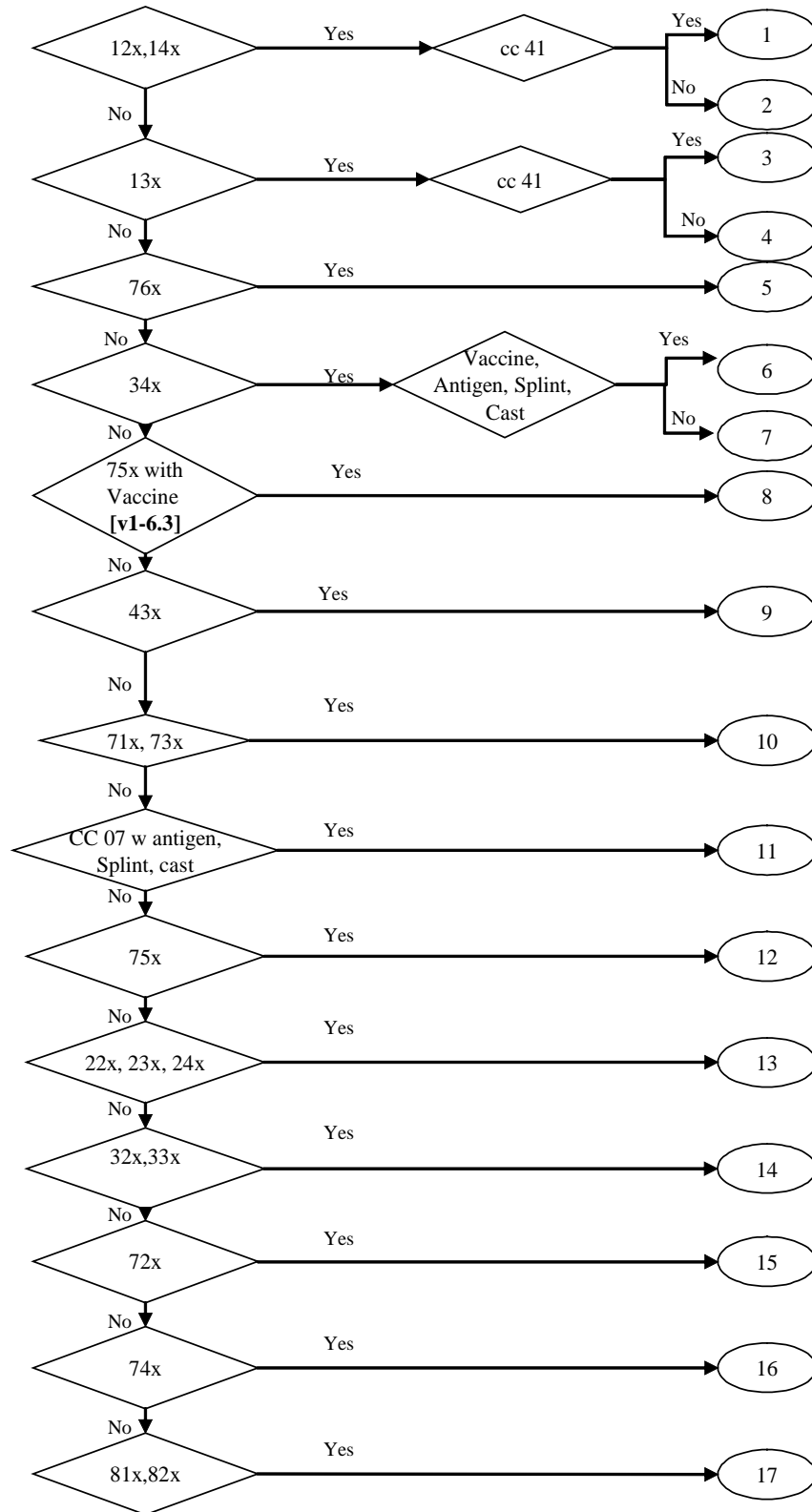

Appendix F(b) - OCE Edits Applied by Non-OPPS Hospital Bill Type [OPPS flag = 2]

FLOW CHART CELL (*) Provider/Bill Types	Proc [8, 9, 11, 12, 50, 53, 54, 69]	Dx [1-3, 5]	HCPC [6]	Non-Mcare [28]	Proc & Modifier [18]	HCPC Reg'd [48 ^a]	Modifier [17, ^b 22]	CCI [19, 20, 39, 40]	^a Line Item Date [23]	Units [15]	Rev Code [41, 65]	Age, Sex [25, 26]	Partial Hosp [29-34]	APC [21, 27, 42]	MH [35, 63, 64]	Bill Type [46]	APC/ASC buffer completed	FDA/NCD [67, 68]	DME (61); Not FI (72)	Opps Proc (55)		
	1 12x&14x w cond code 41/OPPS flag = 2	No	No	No		No	No	No	No	No	No	No	No	No	No	No	No	Yes	No	No	No	No
2 12x&14x w.o cond code 41/OPPS flag = 2	Yes	Yes	Yes		Yes	No	No	Yes	No	Yes	Yes	Yes		Yes	No	No	No	No	No	Yes	No	Yes
3 13x w condition code 41/OPPS flag = 2	Yes	Yes	Yes		Yes	No	No	Yes	No	Yes	Yes	Yes		Yes	No	No	No	No	No	Yes	No	Yes
4 13x w.o cond code 41/OPPS flag = 2	Yes	Yes	Yes		Yes	No	No	Yes	No	Yes	Yes	Yes		Yes	No	No	No	No	No	Yes	No	Yes
5 85x/OPPs flag = 2	Yes	Yes	Yes		Yes	No	No	Yes	No	Yes	Yes	Yes		Yes	No	No	No	No	No	Yes	No	Yes ^d
6 83x/OPPs flag = 2	Yes	Yes	Yes		Yes	No	No	Yes	No	Yes	Yes	Yes		Yes	No	No	No	No	Yes	Yes	No	Yes

(*) FLOW CHART CELLS ARE IN HIERARCHICAL ORDER

Yes = edits apply, No = edits do not apply

Edit 10, and Edits 23 and 24 for From/Through dates, are not dependent on AppxF

^a if edit 23 is not applied, the lowest service (or From) date is substituted for invalid dates, and processing continues.

^b Bypass edit 22 if Revenue code is 540 ^c Edit 53 is not applicable to bill type 13x or 85x

^d Bypass edit 72 if TOB is 85x and revenue code is 096x, 097x or 098x

Appendix G [OPPS Only]

The payment adjustment flag for a line item is set based on the criteria in the following chart:

Criteria	Payment Adjustment Flag Value
Status indicator G	1
Status indicator H	2
Status indicator J ¹	3
Code is flagged as 'deductible not applicable'	4
Blood product with modifier BL on RC 38X line ²	5
Blood product with modifier BL on RC 39X line ²	6
Item provided without cost to provider	7
All others	0

¹ Status indicator J was replaced by status indicator G starting in April 2002 (V3.0)

² See Appendix J for assignment logic (v6.2)

Appendix H [OPPS Only] OCE Observation Criteria

Rules:

1. Code G0378 is used to identify all outpatient observations, regardless of the reason for observation (diagnosis) or the duration of the service.
2. Code G0379 is used to identify direct admission from a physician's office to observation care, regardless of the reason for observation.
3. Code G0378 has default Status Indicator "Q" and default APC 0
 - a. If the criteria are met for payable observation, the SI is changed to "S" and APC 339 is assigned.
 - b. If the criteria for payable observation are not met, the SI is changed to "N".
4. Code G0379 has default Status Indicator "Q" and default APC 0
 - a. If associated with a payable observation (payable G0378 present on the same day), the SI for G0379 is changed to "N".
 - b. If the observation on the same day is not payable, the SI is changed to "V" and APC 604 is assigned.
 - c. If there is no G0378 on the same day, the claim is returned to the provider.
5. Observation logic is performed only for claims with bill type 13x, with or without condition code 41.
6. Lines with G0378 and G0379 are rejected if the bill type is not 13x, or 85x.
7. If any of the criteria for separately payable observation is not met, the observation is packaged, or the claim or line is suspended or rejected according to the disposition of the observation edits.
8. In order to qualify for separate payment, each observation must be paired with a unique E/M or critical care
 - a. (C/C) visit, or with code G0379 (Direct admission from physician's office).
E/M or C/C visit is required the day before or day of observation; Direct admission is required on the day of observation.
9. If an observation cannot be paired with an E/M or C/C visit or Direct admission, the observation is packaged.
10. E/M or C/C visit or Direct admission on the same day as observation takes precedence over E/M or C/C visit on the day before observation.
11. E/M, C/C visit or Direct admission that have been denied or rejected, either externally or by OCE edits, are ignored.
12. Both the associated E/M or C/C visit (APCs 604-616, 617) and observation are paid separately if the criteria are met for separately payable observation.
13. If a "T" procedure occurs on the day of or the day before observation, the observation is packaged.
14. Multiple observations on a claim are paid separately if the required criteria are met for each one.
15. If there are multiple observations within the same time period and only one meets the criteria for separate APC payment, the observation with the most hours is considered to have met the criteria, and the other observations will be packaged.
16. Observation date is assumed to be the date admitted for observation.
17. The diagnoses (patient's reason for visit or principal) required for the separately payable observation criteria are:

Chest Pain	Asthma	CHF
<u>4110</u> , 1, 81, 89	<u>49301</u> , 02, 11, 12, 21, 22, 91, 92	3918
<u>4130</u> , 1, 9		39891
<u>78605</u> , 50, 51, 52, 59		<u>40201</u> , 11, 91
		<u>40401</u> , 03, 11, 13, 91, 93
		<u>4280</u> , 1, 9, 20-23, 30-33, 40-43

18. The APCs required for the observation criteria to identify E/M or C/C visits are 604- 616, 617.

Appendix H (cont'd) OCE Observation Criteria

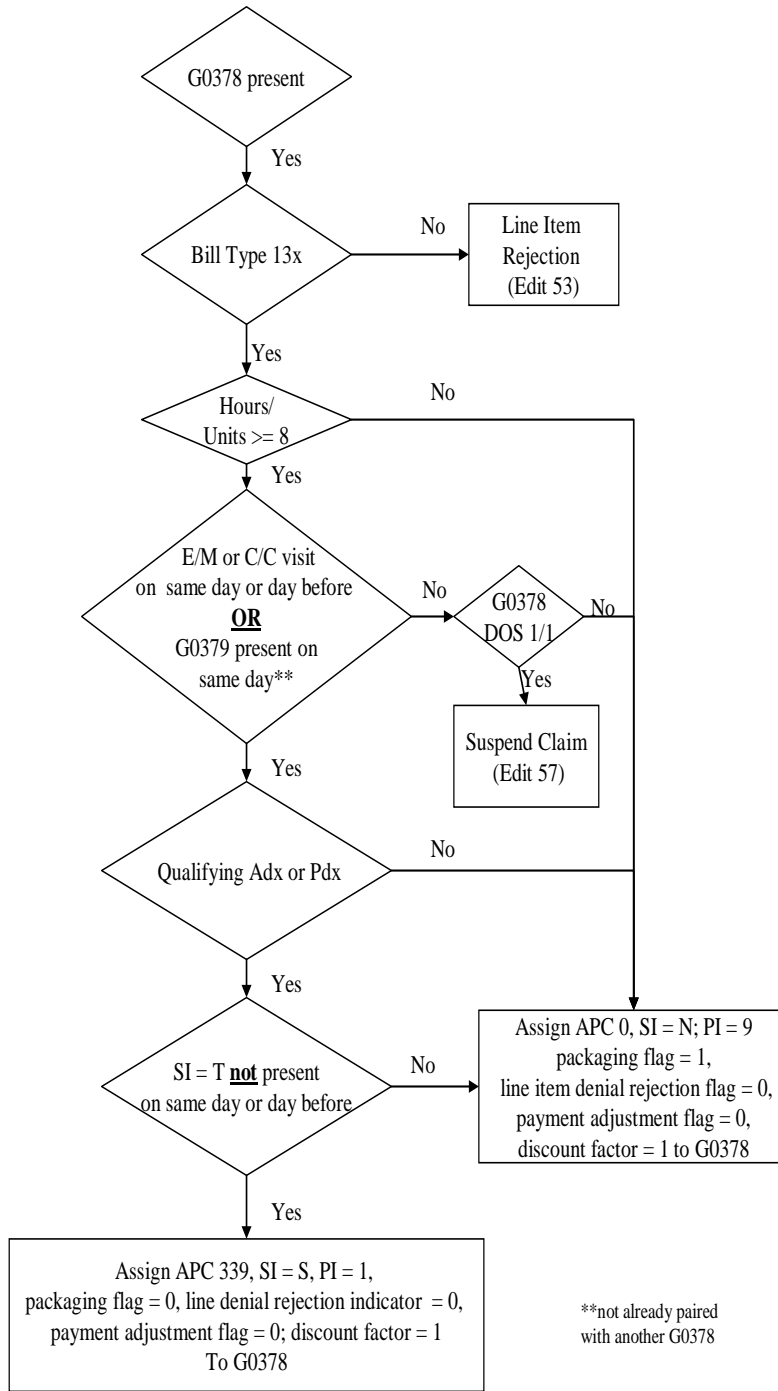

Appendix H (cont'd) Direct Admission Logic

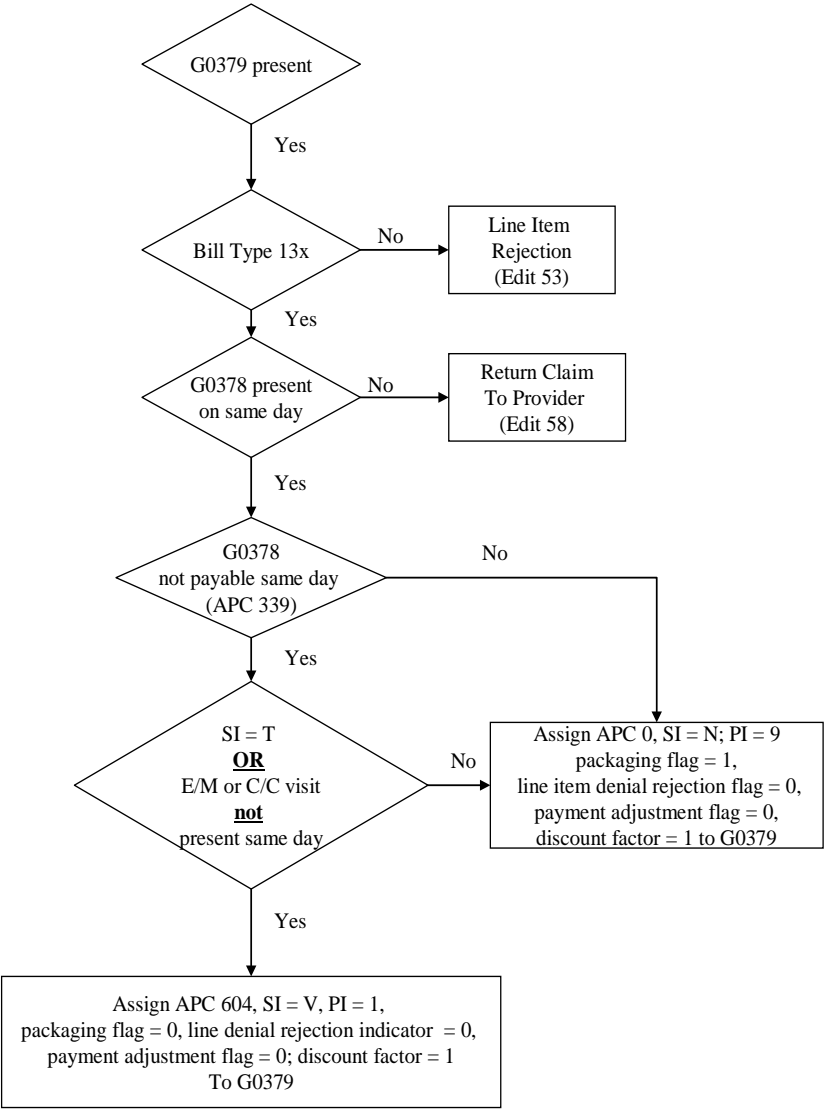

Appendix I [OPPS Only]

Drug Administration (v6.0 – v7.3 only)

For each APC X subjected to Y maximum allowed units do the following (each day);

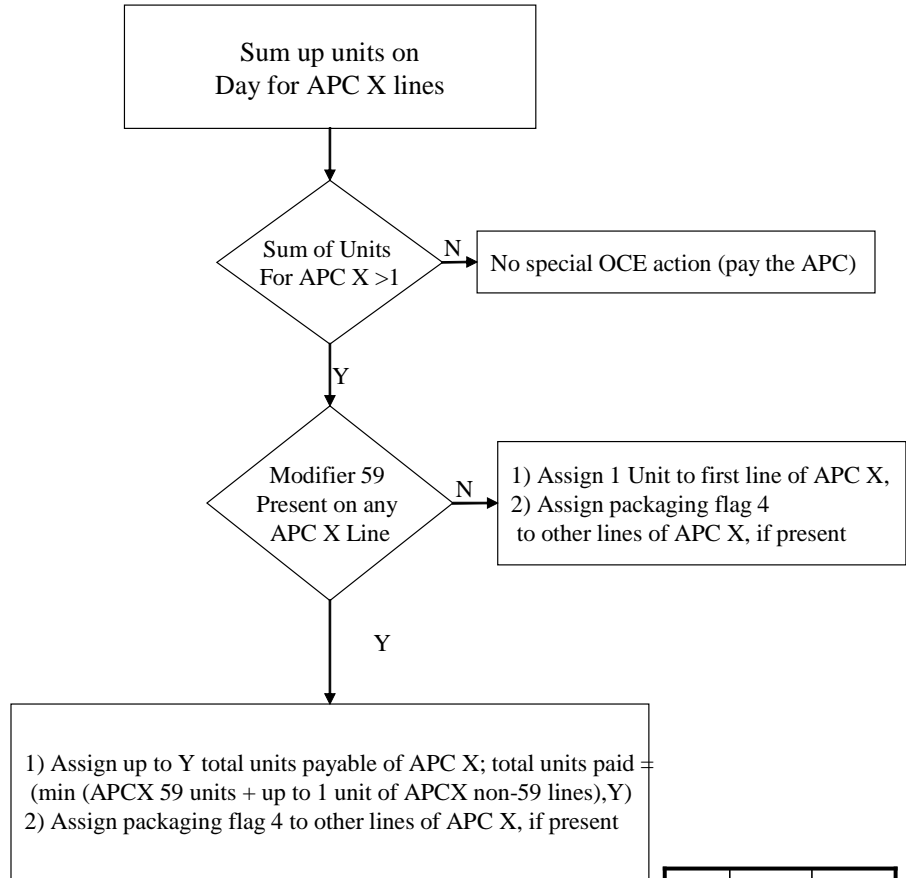

DA APC	Max APC units without modifier 59	Max APC units with modifier 59
116	1	2
117	1	2
120	1	4

Appendix J [OPPS Only]

Billing for blood/blood products

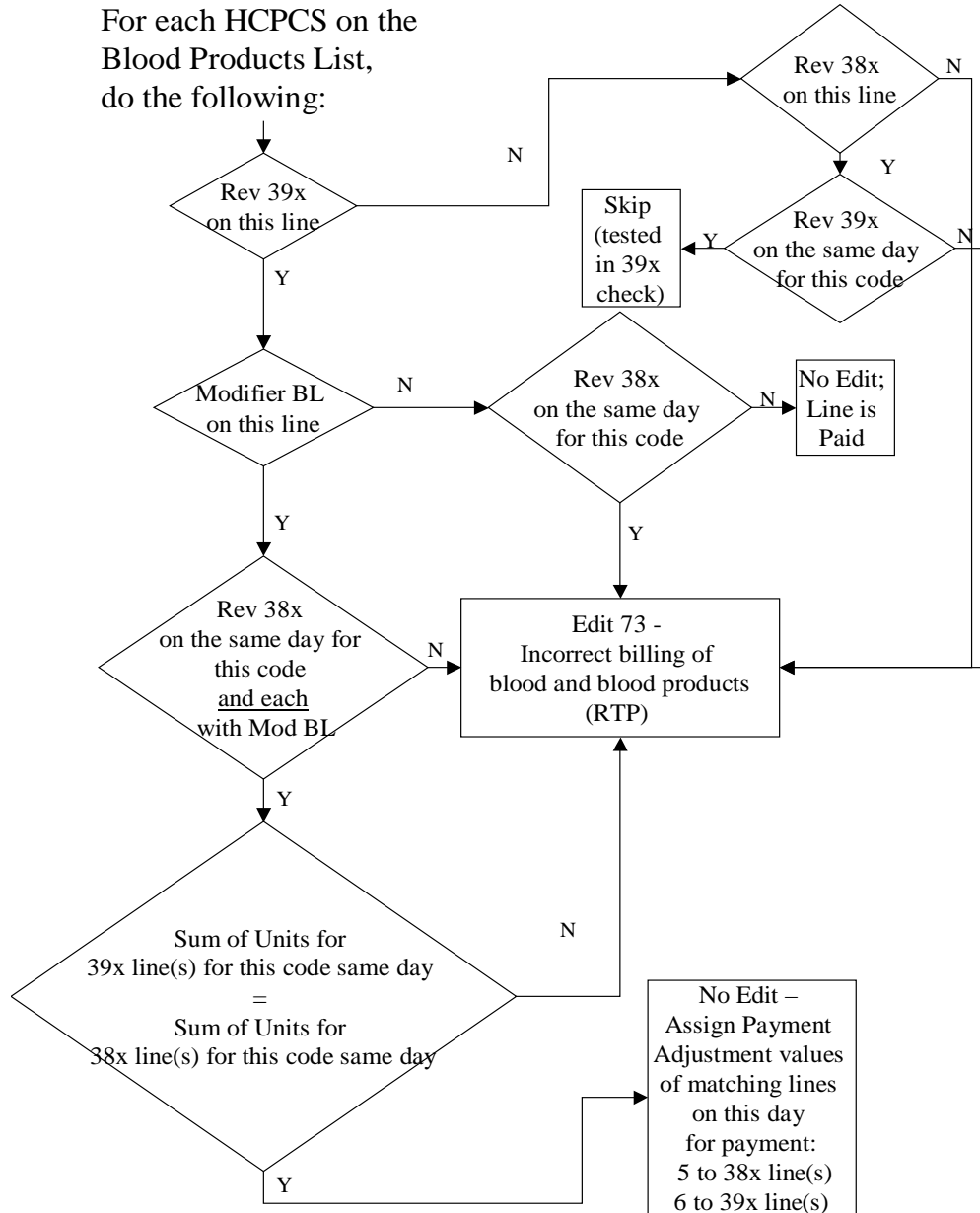

Appendix K OCE overview

1. If claim from/through dates span more than one day, subdivide the line items on the claim into separate days based on the calendar day of the line item service date.
2. Assign the default values to each line item in the APC/ASC return buffer. The default values for the APC return buffer for variables not transferred from input, or not pre-assigned, are as follows:

Payment APC/ASC	00000
HCPCS APC	00000
Status indicator	W
Payment indicator	3
Discounting formula number	1
Line item denial or rejection flag	0
Packaging flag	0
Payment adjustment flag	0
Payment method flag	Assigned in steps 8, 20 and 21

3. If no HCPCS code is on a line item and the revenue code is from one of four specific lists, then assign the following values to the line item in the APC return buffer.

	N-list	E-list	B-list	F-list
HCPCS APC	00000	00000	00000	00000
Payment APC:	00000	00000	00000	00000
Status Indicator:	N	E	B	F
Payment Indicator	9	3	3	4
Packaging flag:	1	0	0	0

If there is no HCPCS code on a line, and the revenue center is not on any of the specified lists, assign default values as follows:

HCPCS APC	00000
Payment APC:	00000
Status Indicator:	Z
Payment Indicator	3
Packaging flag:	0

If the HCPCS code is invalid, or the revenue code is invalid and the HCPCS is blank, assign default values as follows:

HCPCS APC	00000
Payment APC:	00000
Status Indicator:	W
Payment Indicator	3
Packaging flag:	0

For claims with OPSS flag = “1”:

4. If applicable based on Appendix F, assign HCPCS APC in the APC/ASC return buffer for each line item that contains an applicable HCPCS code.

5. If procedure with status indicator “C” and modifier CA is present on a claim and patient status = 20, assign payment APC 375 to “C” procedure line and set the discounting factor to 1. Change SI to “N” and set the packaging flag to 1 for all other line items occurring on the same day as the line item with status indicator “C” and modifier CA. If multiple lines, or one line with multiple units, have SI = C and modifier CA, generate edit 60 for all lines with SI = C and modifier CA.

Appendix K

OCE Overview (cont'd)

6. If edit 18 is present on a claim, generate edit 49 for all other line items occurring on the same day as the line item with edit 18, and set the line item denial or rejection flag to 1 for each of them. Go to step 15.
7. If all of the lines on the claim are incidental, and all of the line item action flags are zero, generate edit 27. Go to step 15.
8. If the line item action flag for a line item has a value of 2 or 3 then reset the values of the Payment APC and HCPCS APC to 00000, and set the payment method flag to 4. If the line item action flag for a line item has a value of 4, set the payment method flag to 0. Ignore line items with a line item action flag of 2, 3 or 4 in all subsequent steps.
9. If bill type is 13x and condition code = 41, or type of bill = 76x, apply partial hospitalization logic from Appendix C. Go to step 11.
10. If bill type is 12x, 13x or 14x without condition code 41 apply mental health logic from Appendix C.
11. If bill type is 13x apply observation logic from Appendix H.
12. If code is on the “sometimes therapy” list, reassign the status indicator to A, APC 0 when there is a therapy revenue code or a therapy modifier on the line.
13. If the payment APC for a line item has not been assigned a value in step 9 thru 13, set payment APC in the APC return buffer for the line item equal to the HCPCS APC for the line item.
14. If edits 9, 13, 19, 20, 21, 28, 39, 40, 45, 47, 49, 50, 53, 64, 65, 67, 68, 69, 76 are present in the edit return buffer for a line item, the line item denial or rejection flag for the line item is set to 1.
15. Compute the discounting formula number based on Appendix D for each line item that has a status indicator of “T”, a modifier of 52, 73 or 50, or is a non type “T” bilateral procedure, or is a non-type “T” procedure with modifier 52 or 73. Note: If the SI or APC of a code is changed during claims processing, the newly assigned SI or APC is used in computing the discount formula. Line items that meet any of the following conditions are not included in the discounting logic.
 - Line item action flag is 2, 3, or 4
 - Line item rejection disposition or line item denial disposition in the APC/ASC return buffer is 1 and the line item action flag is not 1
 - Packaging flag is not 0 or 3
16. If the packaging flag has not been assigned a value of 1 or 2 in previous steps and the status indicator is “N”, then set the packaging flag for the line item to 1.

17. If the submitted charges for HCPCS surgical procedures (SI = T, or SI = S in code range 10000-69999) is less than \$1.01 for any line with a packaging flag of 0, then reset the packaging flag for that line to 3 when there are other surgical procedures on the claim with charges greater than \$1.00.
18. For all bill types where APCs are assigned, apply drug administration APC consolidation logic from appendix I. (v6.0 – v7.3 only)
19. Set the payment adjustment flag for a line item based on the criteria in Appendix G and Appendix J.
20. Set the payment method flag for a line item based on the criteria in Appendix E(a). If any payment method flag is set to a value that is greater than zero, reset the HCPCS and Payment APC values for that line to '00000'.
21. If the line item denial or rejection flag is 1 or 2 and the payment method flag has been set to 2 in the previous step, reset the payment method flag to 3.

For claims with OPPS flag = “2”:

1. If applicable based on Appendix F (b), assign Payment ASC payment group (in the Payment APC/ASC field) in the APC/ASC return buffer for each line item that contains an applicable HCPCS code.
2. Set Non-OPPS bill type flag as applicable, based on the presence or absence of ASC procedures.
3. If the line item action flag for a line item has a value of 2 or 3 then reset the values of the Payment ASC to 00000, and set the payment method flag to 4. Ignore line items with a line item action flag of 2, 3 or 4 in all subsequent steps.
4. If edits 9, 28, 50, 65, 67, 68, 69 are present in the edit return buffer for a line item, the line item denial or rejection flag for the line item is set to 1.
5. Set the payment method flag for a line item based on the criteria in Appendix E (b).
6. If the line item denial or rejection flag is 1 or 2 and the payment method flag has been set to 2 in the previous step, reset the payment method flag to 3.

Appendix L

Summary of Modifications

The modifications of the OCE for the July 2007 release (V8.2) are summarized in the attached table.

Readers should also read through the specifications and note the highlighted sections, which also indicate change from the prior release of the software.

Some OCE modifications in the release may also be retroactively added to prior releases. If so, the retroactive date will appear in the 'Effective Date' column.

	Mod. Type	Effective Date	Edit	
1	Logic	7/1/07		Modify the software program to add the processing of claims from hospitals that are not subject to OPSS (bill types 12x, 13x, 14x, 83x and 85x), for dates of service beginning 7/1/07 (in addition to all other institutional outpatient providers).
2	Logic	7/1/07		Activate the OPSS/Non-OPSS flag in the OCE control block.
3	Logic	7/1/07		Assign ASC group number and apply specified edits (appendix F(b)) to claims from Non-OPSS hospitals (OPSS flag = 2).
4	Logic	7/1/07		Rename appendix F to "appendix F(a)" Add appendix F(b) for editing of claims from Non-OPSS hospitals Rename appendix E to "appendix E (a)" Add appendix E(b) for processing of claims from Non-OPSS hospitals Modify appendix K to add Non-OPSS hospital claims
5	Logic	7/1/07		Interface change – New, 1-byte field added to the claim return buffer for the Non-OPSS bill type flag. Flag to be assigned by the OCE based on the presence/absence of ASC procedures on Non-OPSS hospital claims. Values: 1 = Bill type should be 83x 2 = Bill type should not be 83x

6	Content	7/1/07		Make HCPCS/APC/SI changes as specified by CMS
7	Content		19, 20, 39, 40	Implement version 13.1 of the NCCI file, removing all code pairs which include Anesthesia (00100-01999), E&M (92002-92014, 99201-99499), or MH (90804-90911).
8	Content			Add specified modifiers to the valid modifier list (KG, KK, KL, KT, KU, 1P, 2P, 3P, 8P)
9	Content		71	Update procedure/device edit requirements
10	Content	8/1/00	41	Remove invalid code 0620 from the list of valid revenue codes
11	Doc	7/1/07		Change the name of the software program from Outpatient Code Editor with Ambulatory Payment Classification (OCE/APC) to Integrated Outpatient Code Editor (IOCE). No change to version numbering or date ranges.
12	Doc	7/1/07		Merge the Installation and User Manuals for the OPSS OCE and the Non-OPSS OCE into a single set of manuals for the Integrated OCE.

Final
Summary of Data Changes
Integrated OCE v 8.2
Effective July 1, 2007

Table of Contents

CPT codes, descriptions, and material only are Copyright 2006 American Medical Association. All Rights Reserved. No fee schedules, basic units, relative values, or related listings are included in CPT. The AMA assumes no liability for the data contained herein. Applicable FARS/DFARS restrictions apply to government use.

DEFINITIONS.....	3
APC CHANGES.....	4
<u>Added APCs</u>	4
<u>Deleted APCs</u>	4
<u>APC Description Changes</u>	4
<u>APC Status Indicator Changes</u>	5
HCPCS/CPT PROCEDURE CODE CHANGES.....	5
<u>Added HCPCS/CPT Procedure Codes</u>	5
<u>Deleted HCPCS/CPT Procedure Codes</u>	6
<u>HCPCS Description Changes</u>	9
<u>HCPCS Changes- APC, Status Indicator and/or Edit Assignments</u>	10
<u>Hcpcs Edit Changes</u>	10
<u>Procedure/ Device Pair Changes</u>	11
MODIFIERS	11
<u>Added Modifiers</u>	11
REVENUE CODES.....	11
<u>Deleted Revenue Codes</u>	11
ASC ASSIGNMENTS.....	12

DEFINITIONS

- A blank in a field indicates ‘no change’
- The “old” column describes the attribute prior to the change being made in the current update, which is indicated in the “new” column. If the effective date of the change is the same as the effective date of the new update, ‘old’ describes the attribute up to the last day of the previous quarter. If the effective date is retroactive, then ‘old’ describes the attribute for the same date in the previous release of the software.
- “Unassigned”, “Pre-defined” or “Placeholder” in APC or HCPCS descriptions indicates that the APC or HCPCS code is inactive. When the APC or HCPCS code is activated, it becomes valid for use in the OCE, and a new description appears in the “new description” column, with the appropriate effective date.
- Activation Date (ActivDate) indicates the mid-quarter date of FDA approval for a drug, or the mid-quarter date of a new or changed code resulting from a National Coverage Determination (NCD). The Activation Date is the date the code becomes valid for use in the OCE. If the Activation Date is blank, then the effective date takes precedence.
- Termination Date (TermDate) indicates the mid-quarter date when a code or change becomes inactive. A code is not valid for use in the OCE after its termination date.

APC CHANGES

Added APCs

The following APC(s) were added to the IOCE, **effective 07-01-07**

APC	APCDesc	StatusIndicator
00943	Octagam Injection	K
00944	Gammagard Liquid injection	K
00945	Rhophylac injection	K
00946	HepaGam B IM Injection	K
00947	Flebogamma injection	K
00948	Gamunex injection	K
00951	Reclast injection	K
02638	Brachytx, stranded, I-125	H
02639	Brachytx, non-stranded,I-125	H
02640	Brachytx, stranded, P-103	H
02641	Brachytx, non-stranded,P-103	H
02642	Brachytx, stranded, C-131	H
02643	Brachytx, non-stranded,C-131	H
02698	Brachytx, stranded, NOS	H
02699	Brachytx, non-stranded, NOS	H

Deleted APCs

The following APC(s) were deleted from the IOCE, **effective 07-01-07**

APC	APCDesc
01718	Brachytx source, Iodine 125
01720	Brachytx sour, Palladium 103
02633	Brachytx source, Cesium-131
02732	Immune globulin, liquid

APC Description Changes

The following APC(s) had description changes, **effective 07-01-07**

APC	Old Description	New Description
01716	Brachytx source, Gold 198	Brachytx, non-str, Gold-198
01717	Brachytx source, HDR Ir-192	Brachytx, non-str, HDR Ir-192
01719	Brachytx sour,Non-HDR Ir-192	Brachytx, NS, Non-HDRIr-192
02616	Brachytx source, Yttrium-90	Brachytx, non-str,Yttrium-90
02634	Brachytx source, HA, I-125	Brachytx, non-str, HA, I-125
02635	Brachytx source, HA, P-103	Brachytx, non-str, HA, P-103
02636	Brachytx linear source,P-103	Brachy linear, non-str,P-103
02637	Brachytx, Ytterbium-169	Brachy,non-str,Ytterbium-169

APC Status Indicator Changes

The following Apc(s) had Status Indicator changes, **effective 07-01-07**

APC	Old SI	New SI
00825	K	G

HCPCS/CPT PROCEDURE CODE CHANGES

Added HCPCS/CPT Procedure Codes

The following new HCPCS/CPT code(s) were added to the IOCE, **effective 01-01-07**

HCPCS	CodeDesc	SI	APC	Edit	ASC	ActivDate	TermDate
3150F	Forceps esoph biopsy done	M	00000	72	0		

The following new HCPCS/CPT code(s) were added to the IOCE, **effective 07-01-07**

HCPCS	CodeDesc	SI	APC	Edit	ASC	ActivDate	TermDate
0178T	64 Lead ECG w I&R	B	00000	62	0		
0179T	64 Lead ECG w tracing	X	00100		0		
0180T	64 Lead ECG w I&R only	B	00000	62	0		
0181T	Corneal hysteresis	S	00230		0		
0182T	Hdr elec brachytherapy	S	01519		0		
3155F	Cytogen test marrow b/4 tx	M	00000	72	0		
3160F	Doc fe+ stores b/4 epo thx	M	00000	72	0		
3170F	Flow cyto done b/4 tx	M	00000	72	0		
3200F	Barium swallow test not req	M	00000	72	0		
3210F	Grp a strep test performed	M	00000	72	0		
4090F	Pt rcvng epo thxpy	M	00000	72	0		
4095F	Pt not rcvng epo thxpy	M	00000	72	0		
4100F	Biphos thxpy vein ord/rec'vd	M	00000	72	0		
4110F	Int. mam art used for cabg	M	00000	72	0		
4115F	Beta blkcr admin w/in 24 hrs	M	00000	72	0		
4120F	Antibiot rx'd/given	M	00000	72	0		
4124F	Antibiot not rx'd/given	M	00000	72	0		
C2638	Brachytx, stranded, I-125	H	02638	55	0		
C2639	Brachytx, non-stranded,I-125	H	02639	55	0		
C2640	Brachytx, stranded, P-103	H	02640	55	0		
C2641	Brachytx, non-stranded,P-103	H	02641	55	0		
C2642	Brachytx, stranded, C-131	H	02642	55	0		
C2643	Brachytx, non-stranded,C-131	H	02643	55	0		
C2698	Brachytx, stranded, NOS	H	02698	55	0		
C2699	Brachytx, non-stranded, NOS	H	02699	55	0		
C9728	Place device/marker,non pros	T	00156	55	0		
G8370	Asthma pt w survey not docum	M	00000	72	0		
G8371	Chemother not rec stg3 colon	M	00000	72	0		
G8372	Chemother rec stg 3 colon ca	M	00000	72	0		
G8373	Chemo plan docum prior chemo	M	00000	72	0		
G8374	Chemo plan not doc prior che	M	00000	72	0		

HCPCS	CodeDesc	SI	APC	Edit	ASC	ActivDate	TermDate
G8375	CLL pt w/o doc flow cytometr	M	00000	72	0		
G8376	Brst ca pt inelig tamoxifen	M	00000	72	0		
G8377	MD doc colon ca pt inelig ch	M	00000	72	0		
G8378	MD doc pt inelig rad therapy	M	00000	72	0		
G8379	Radiat tx recom doc12mo ov	M	00000	72	0		
G8380	Pt w stgIC-3Brst ca w/o tam	M	00000	72	0		
G8381	Pt w stgIC-3Brst ca rec tam	M	00000	72	0		
G8382	MM pt w/o doc IV biphophon	M	00000	72	0		
G8383	Radiation rec not doc12mo ov	M	00000	72	0		
G8384	MDS pt w/o base cytogen test	M	00000	72	0		
G8385	Diab pt w nodoc Hgb A1c 12m	M	00000	72	0		
G8386	Diab pt w nodoc LDL 12m	M	00000	72	0		
G8387	ESRD pt w Hct/Hgb not docume	M	00000	72	0		
G8388	ESRD pt w URR/Ktv not doc el	M	00000	72	0		
G8389	MDS pt no doc Fe prior EPO	M	00000	72	0		
K0553	Combination oral/nasal mask	Y	00000	61	0		
K0554	Repl oral cushion combo mask	Y	00000	61	0		
K0555	Repl nasal pillow comb mask	Y	00000	61	0		
Q4087	Octagam Injection	K	00943		0		
Q4088	Gammagard Liquid injection	K	00944		0		
Q4089	Rhophylac injection	K	00945		0		
Q4090	HepaGam B IM Injection	K	00946		0		
Q4091	Flebogamma injection	K	00947		0		
Q4092	Gamunex injection	K	00948		0		
Q4093	Albuterol inh non-comp con	B	00000	62	0		
Q4094	Albuterol inh non-comp u d	B	00000	62	0		
Q4095	Reclast injection	K	00951		0		
S2066	Breast GAP flap reconst	E	00000	9	0		
S2067	Breast "stacked" DIEP/GAP	E	00000	9	0		
S3800	Genetic testing ALS	E	00000	9	0		
S3905	Auto handheld diag nerv test	E	00000	9	0		
S9152	Speech therapy, re-eval	E	00000	9	0		

Deleted HCPCS/CPT Procedure Codes

The following HCPCS/CPT code(s) were deleted from the IOCE, **effective 04-01-07**

HCPCS	CodeDesc
J7319	Sodium Hyaluronate Injection

The following HCPCS/CPT code(s) were deleted from the IOCE, **effective 07-01-07**

HCPCS	CodeDesc
0024T	Transcath cardiac reduction
0133T	Esophageal implant injexn
3101F	Intl carot blk 30-99% range
3102F	Int carot blk < 30%
3143F	Doc order barium swallow tst
C1718	Brachytx source, Iodine 125
C1720	Brachytx sour, Palladium 103
C2633	Brachytx source, Cesium-131

HCPCS	CodeDesc
G8158	Pt recd CABG w/ IMA
G8160	Pt inelig for CABG w/IMA
G8161	Iso CABG pt rec preop bblock
G8163	Iso CABG pt inelig for preo
G8191	Antibiotic given prior surg
G8192	Antib given prior surg incis
G8194	Pt not elig for antibiotic
G8195	Antibiotic given prior surg
G8197	Antib order prior to surg
G8198	Cefazolin documented ordered
G8199	Cefazolin given prophylaxis
G8201	Pt not eligi for cefazolin
G8202	Order given to d/c antibio
G8203	Antib was D/C 24hrs surg tim
G8205	Pt not eligi for proph antib
G8206	MD doc prophylactic AB given
G8207	Clini doc order to D/C antib
G8208	Clini doc AB was D/C 48 h
G8210	Clini doc pt ineligib anti
G8211	Clini doc proph AB giv
G8212	Clini order given for VTE
G8213	Clini given VTE prop
G8215	Clini doc pt inelig VTE
G8216	Pt received DVT prophylaxis
G8218	Pt inelig DVT prophylaxis
G8222	Pt prescribe platelet at D/C
G8224	Pt inelig for antiplat proph
G8225	Pt prescrib anticoag at D/C
G8227	Pt not doc to have perm/AF
G8228	Clin pt inelig anticoag D/C
G8229	Pt doc to have admin t-PA
G8230	Pt inelig t-PA isch strok>3h
G8232	Pt received dysphagia screen
G8235	Pt received NPO
G8236	Pt inelig dysphagia screen
G8237	Pt doc rec rehab serv
G8239	Inter carotid stenosis <30%
G8241	Pt inelig candidate ito meas
G8242	Pt doc to have CT/MRI w/les
G8245	Clini doc prese/abs alarm
G8247	Pt w/alarm symp upper endo
G8249	Pt inelig for upper endo
G8250	Pt w/Barretts esoph endo re
G8252	Pt inelig for esophag biop
G8253	Pt rec order for barium
G8255	Clini doc pt inelig bar swal
G8256	Clini doc rev D/C meds w/med
G8258	Pt inelig for d/c meds rev
G8259	Pt doc to hav decision maker
G8261	Clin doc pt inelig dec maker
G8262	Pt doc assess uriny incon

HCPCS	CodeDesc
G8264	Pt inelig assess urinary inc
G8265	Pt doc rec charc urin incon
G8267	Pt doc rec plan urinary inco
G8269	Clin not prov care urin inco
G8270	Pt receiv screen for fall
G8272	Clin doc pt inelig fall risk
G8273	Clin not prov care scre fall
G8275	Pt hx w/ new moles
G8277	Pt inelig for assess mole
G8278	Pt doc rec PE skin
G8280	Pt inelig PE skin
G8281	Pt rec counsel for self-exam
G8283	Pt inelig for counsel
G8284	Pt doc to rec pres osteo
G8286	Pt inelig to rec pres osteo
G8287	Clin not prov care for pharm
G8288	Pt doc rec Ca/Vit D
G8290	Clin doc pt inelig Ca/Vit D
G8291	Clin no pro care pt Ca/Vit D
G8292	COPD pt w/spir results
G8294	COPD pt inelig spir results
G8295	COPD pt doc bronch ther
G8297	COPD pt inelig bronch therap
G8300	Pt inelig for optic nerv eva
G8301	Clin not prov care POAG
G8309	Pt doc rec antioxidant
G8311	Pt inelig for antioxidant
G8312	Clin no prov care for antiox
G8313	Pt doc rec macular exam
G8315	Clin doc pt inelig mac exam
G8316	Clin no pro care for mac deg
G8317	Pt doc to have visual func
G8319	Pt inelig for vis func stat
G8320	Clin not prov care catarac
G8322	Pt not doc pre axial leng
G8323	Pt inelig for pre surg axial
G8324	Clin not prov care for IOL
G8325	Pt rec fund exam prior surg
G8327	Pt inelig for pre surg fundu
G8328	Clin not prov care fund eval
G8329	Pt doc rec dilated macular
G8331	Pt inelig dilate fundus
G8332	Clin prov no care diabetic r
G8333	Pt doc to have macular exam
G8335	Clin doc pt inelig macular
G8336	Clin did not pro care diabet
G8337	Clin doc pt was test osteo
G8339	Pt inelig for test osteo
G8340	Pt doc have DEXA
G8342	Clin doc pt inelig DEXA
G8343	Clin not prov care DEXA

HCPCS	CodeDesc
G8344	Pt doc have DEXA perform
G8346	Clin doc pt inelig DEXA
G8347	Clin not prov care DEXA
G8348	Int carotid stenosis meas
G8349	Pt inelig for doc of alarm
G8350	Pt doc 12 lead ECG
G8352	Pt inelig for ECG
G8353	Pt doc rec aspirin 24hrs ER
G8355	Clin doc pt inelig aspirin
G8356	Pt doc to have ECG
G8358	Clin doc pt inelig ECG
G8359	Pt doc vital signs recorded
G8361	Pt doc to have 02 SAT assess
G8363	Clin doc pt inelig 02 SAT
G8364	Pt doc mental status assess
G8366	Pt doc to have empiric AB
G8368	Clin doc pt inelig empiri AB
S2078	Lap supracerv hysterectomy

HCPCS Description Changes

The following code descriptions were changed, **effective 01-01-07**

HCPCS	Old Description	New Description
1065F	Ischm stroke symp <3 hrs b/4	Ischm stroke symp lt3 hrsb/4
1066F	Ischm stroke symp >=3 hrs b/	Ischm stroke symp ge3 hrsb/4
3044F	HG a1c level < 7.0%	HG a1c level lt 7.0%
3074F	Syst bp < 130 mm hg	Syst bp lt 130 mm hg
3075F	Syst bp >=130-139 mm hg	Syst bp ge 130-139 mm hg
3111F	Ct/mri brain done w/in 24hrs	CT/MRI brain done w/in 24hrs
3112F	Ct/mri brain done > 24 hrs	CT/MRI brain done GT24 hrs
3120F	12-lead ecg performed	12-Lead ECG performed
3130F	Upper gi endoscopy performed	Upper GI endoscopy performed
3132F	Doc ref. upper gi endoscopy	Doc ref. upper GI endoscopy

The following code descriptions were changed, **effective 07-01-07**

HCPCS	Old Description	New Description
1100F	Pt falls assess-doc'd>=2+/yr	Ptfalls assess-doc'd ge2+/yr
1101F	Pt falls assessed-doc'd<=1/y	Pt falls assess-doc'd le1/yr
3100F	Carot blk doc'd w/ carot ref	Image test ref carot diam
3140F	Forceps esoph biopsy done	Upper GI endo shows barrtt's
3141F	Upper gi endo shows barrtt's	Upper GI endo not barrtt's
3142F	Upper gi endo not barrtt's	Barium swallow test ordered
4007F	Antiox vit/min supp rx'd	Areds/anitox vit/min rx'd
C1716	Brachytx source, Gold 198	Brachytx, non-str, Gold-198
C1717	Brachytx source, HDR Ir-192	Brachytx,non-str, HDR Ir-192
C1719	Brachytx sour,Non-HDR Ir-192	Brachytx, NS, Non-HDR Ir-192
C2616	Brachytx source, Yttrium-90	Brachytx, non-str, Yttrium-90
C2634	Brachytx source, HA, I-125	Brachytx, non-str, HA, I-125
C2635	Brachytx source, HA, P-103	Brachytx, non-str, HA, P-103

HCPCS	Old Description	New Description
C2636	Brachytx linear source,P-103	Brachy linear, non-str,P-103
C2637	Brachytx, Ytterbium-169	Brachy,non-str,Ytterbium-169
S2068	Breast DIEP flap reconstruct	Breast DIEP or SIEA flap

HCPCS Changes- APC, Status Indicator and/or Edit Assignments

The following code(s) had an APC and/or SI and/or edit change, **effective 08-01-00** **A blank in the field indicates no change.

HCPCS	CodeDesc	Old APC	New APC	Old SI	New SI	Old Edit	New Edit
L3215	Orthopedic ftwear ladies oxf			B	E	14	50
L3219	Orthopedic mens shoes oxford			B	E	14	50

The following code(s) had an APC and/or SI and/or edit change, **effective 01-01-06** **A blank in the field indicates no change.

HCPCS	CodeDesc	Old APC	New APC	Old SI	New SI	Old Edit	New Edit
0115T	Med tx mngmt 15 min			B	E	62	50
0116T	Med tx mngmt subsqt			B	E	62	50
0117T	Med tx mngmt addl 15 min			B	E	62	50

The following code(s) had an APC and/or SI and/or edit change, **effective 07-01-07** **A blank in the field indicates no change.

HCPCS	CodeDesc	Old APC	New APC	Old SI	New SI	Old Edit	New Edit
A6200	Compos drsg <=16 no border			A	E	N/A	9
A6201	Compos drsg >16<=48 no bdr			A	E	N/A	9
A6202	Compos drsg >48 no border			A	E	N/A	9
J1567	Immune globulin, liquid	02732	00000	K	E	N/A	28
J7611	Albuterol non-comp con			B	E	62	28
J7612	Levalbuterol non-comp con			B	E	62	28
J7613	Albuterol non-comp unit			B	E	62	28
J7614	Levalbuterol non-comp unit			B	E	62	28
J9261	Nelarabine injection			K	G		
S2068	Breast DIEP or SIEA flap					28	9

Hcpcs Edit Changes

The following code(s) were added to the list of male procedures, **effective 01-01-07**

Hcpcs
19300

The following code(s) were added to the list of female procedures, **effective 01-01-07**

Hcpcs
77057

Procedure/ Device Pair Changes

The following procedure/device code pair requirements were added, **effective 10-01-05**

Proc	Device1
50688	C2625

The following procedure/device code pair requirements were added, **effective 01-01-07**

Proc	Device1
G0392	C1725
G0392	C1874
G0392	C1876
G0392	C1885
G0392	C2625
G0393	C1725
G0393	C1874
G0393	C1876
G0393	C1885
G0393	C2625

MODIFIERS

Added Modifiers

The following modifier(s) were added to the list of valid modifiers, **effective 07-01-07**

modif	ACTIVATIONDATE
1P	0
2P	0
3P	0
8P	0
KG	0
KK	0
KL	0
KT	0
KU	0

REVENUE CODES

Deleted Revenue Codes

The following invalid revenue code was removed from the list of valid revenue codes, **effective 08-01-00**

RevenueCode	SI
0620	E

ASC ASSIGNMENTS

The following code(s) had an ASC assignment, **effective 07-01-07**

HCPCS	ASC
0176T	9
0177T	9
10121	2
10180	2
11010	37
11011	37
11012	37
11042	28
11043	28
11044	52
11404	1
11406	2
11424	2
11426	2
11444	1
11446	2
11450	2
11451	2
11462	2
11463	2
11470	2
11471	2
11604	51
11606	2
11624	2
11626	2
11644	2
11646	2
11770	3
11771	3
11772	3
11960	2
11970	3
11971	1
12005	17
12006	17
12007	17
12016	17
12017	17
12018	17
12020	17
12021	17
12034	17
12035	17
12036	17

HCPCS	ASC
12037	42
12044	17
12045	17
12046	17
12047	42
12054	17
12055	17
12056	17
12057	42
13100	42
13101	42
13102	17
13120	17
13121	17
13122	17
13131	17
13132	17
13133	17
13150	42
13151	42
13152	42
13153	17
13160	2
14000	2
14001	3
14020	3
14021	3
14040	2
14041	3
14060	3
14061	3
14300	4
14350	3
15002	42
15003	42
15004	42
15005	42
15040	17
15050	42
15100	2
15101	3
15110	2
15111	1
15115	2
15116	1
15120	2
15121	3
15130	2
15131	1
15135	2
15136	1

HCPCS	ASC
15150	2
15151	1
15152	1
15155	2
15156	1
15157	1
15200	3
15201	42
15220	2
15221	42
15240	3
15241	42
15260	2
15261	42
15300	42
15301	42
15320	42
15321	42
15330	42
15331	42
15335	42
15336	42
15400	42
15401	42
15420	42
15421	42
15430	42
15431	42
15570	3
15572	3
15574	3
15576	3
15600	3
15610	3
15620	4
15630	3
15650	5
15731	3
15732	3
15734	3
15736	3
15738	3
15740	2
15750	2
15760	2
15770	3
15775	42
15776	42
15820	3
15821	3
15822	3

HCPCS	ASC
15823	5
15824	3
15825	3
15826	3
15828	3
15829	5
15830	3
15832	3
15833	3
15834	3
15835	42
15836	3
15839	3
15840	4
15841	4
15845	4
15847	3
15876	3
15877	3
15878	3
15879	3
15920	37
15922	4
15931	3
15933	3
15934	3
15935	4
15936	4
15937	4
15940	3
15941	3
15944	3
15945	4
15946	4
15950	3
15951	4
15952	3
15953	4
15956	3
15958	4
16025	13
16030	18
19020	2
19100	34
19101	2
19102	34
19103	48
19110	2
19112	3
19120	3
19125	3

HCPCS	ASC
19126	3
19290	1
19291	1
19295	20
19296	9
19297	9
19298	9
19300	4
19301	3
19302	7
19303	4
19304	4
19316	4
19318	4
19324	4
19325	9
19328	1
19330	1
19340	2
19342	3
19350	4
19355	4
19357	5
19366	5
19370	4
19371	4
19380	5
20005	2
20200	2
20205	3
20206	34
20220	37
20225	51
20240	2
20245	3
20250	3
20251	3
20525	3
20650	3
20670	1
20680	3
20690	2
20692	3
20693	3
20694	1
20900	3
20902	4
20910	3
20912	3
20920	4
20922	3

HCPCS	ASC
20924	4
20926	4
20975	10
21010	2
21015	3
21025	2
21026	2
21029	2
21034	3
21040	2
21044	2
21046	2
21047	2
21050	3
21060	2
21070	3
21100	2
21120	7
21121	7
21122	7
21123	7
21125	7
21127	9
21181	7
21206	5
21208	7
21209	5
21210	7
21215	7
21230	7
21235	7
21240	4
21242	5
21243	5
21244	7
21245	7
21246	7
21248	7
21249	7
21267	7
21270	5
21275	7
21280	5
21282	5
21295	1
21296	1
21310	27
21315	27
21320	2
21325	4
21330	5

HCPCS	ASC
21335	7
21336	4
21337	2
21338	4
21339	5
21340	4
21345	7
21355	3
21356	3
21400	2
21401	3
21421	4
21445	4
21450	27
21451	53
21452	2
21453	3
21454	5
21461	4
21462	5
21465	4
21480	27
21485	2
21490	3
21497	2
21501	2
21502	2
21555	2
21556	2
21600	2
21610	2
21700	2
21720	3
21725	16
21800	19
21805	2
21820	19
21925	2
21930	2
21935	3
22305	19
22310	19
22315	19
22505	2
22520	9
22521	9
22522	9
22900	4
23000	2
23020	2
23030	1

HCPCS	ASC
23031	3
23035	3
23040	3
23044	4
23066	2
23075	2
23076	2
23077	3
23100	2
23101	7
23105	4
23106	4
23107	4
23120	5
23125	5
23130	5
23140	4
23145	5
23146	5
23150	4
23155	5
23156	5
23170	2
23172	2
23174	2
23180	4
23182	4
23184	4
23190	4
23195	5
23330	1
23331	1
23395	5
23397	7
23400	7
23405	2
23406	2
23410	5
23412	7
23415	5
23420	7
23430	4
23440	4
23450	5
23455	7
23460	5
23462	7
23465	5
23466	7
23480	4
23485	7

HCPCS	ASC
23490	3
23491	3
23500	19
23505	19
23515	3
23520	19
23525	19
23530	3
23532	4
23540	19
23545	19
23550	3
23552	4
23570	19
23575	19
23585	3
23605	19
23615	4
23616	4
23625	19
23630	5
23650	19
23655	1
23660	3
23665	19
23670	3
23675	19
23680	3
23700	1
23800	4
23802	7
23921	42
23930	1
23931	2
23935	2
24000	4
24006	4
24066	2
24075	2
24076	2
24077	3
24100	1
24101	4
24102	4
24105	3
24110	2
24115	3
24116	3
24120	3
24125	3
24126	3

HCPCS	ASC
24130	3
24134	2
24136	2
24138	2
24140	3
24145	3
24147	2
24155	3
24160	2
24164	3
24201	2
24301	4
24305	4
24310	3
24320	3
24330	3
24331	3
24340	3
24341	3
24342	3
24345	2
24350	3
24351	3
24352	3
24354	3
24356	3
24360	5
24361	5
24362	5
24363	7
24365	5
24366	5
24400	4
24410	4
24420	3
24430	3
24435	4
24470	3
24495	2
24498	3
24500	19
24505	19
24515	4
24516	4
24530	19
24535	19
24538	2
24545	4
24546	5
24560	19
24565	19

HCPCS	ASC
24566	2
24575	3
24576	19
24577	19
24579	3
24582	2
24586	4
24587	5
24600	19
24605	2
24615	3
24620	19
24635	3
24655	19
24665	4
24666	4
24670	19
24675	19
24685	3
24800	4
24802	5
24925	3
25000	3
25020	3
25023	3
25024	3
25025	3
25028	1
25031	2
25035	2
25040	5
25066	2
25075	2
25076	3
25077	3
25085	3
25100	2
25101	3
25105	4
25107	3
25110	3
25111	3
25112	4
25115	4
25116	4
25118	2
25119	3
25120	3
25125	3
25126	3
25130	3

HCPCS	ASC
25135	3
25136	3
25145	2
25150	2
25151	2
25210	3
25215	4
25230	4
25240	4
25248	2
25250	1
25251	1
25260	4
25263	2
25265	3
25270	4
25272	3
25274	4
25275	4
25280	4
25290	3
25295	3
25300	3
25301	3
25310	3
25312	4
25315	3
25316	3
25320	3
25332	5
25335	3
25337	5
25350	3
25355	3
25360	3
25365	3
25370	3
25375	4
25390	3
25391	4
25392	3
25393	4
25400	3
25405	4
25415	3
25420	4
25425	3
25426	4
25440	4
25441	5
25442	5

HCPCS	ASC
25443	5
25444	5
25445	5
25446	7
25447	5
25449	5
25450	3
25455	3
25490	3
25491	3
25492	3
25505	19
25515	3
25520	19
25525	4
25526	5
25535	19
25545	3
25565	19
25574	3
25575	3
25605	19
25606	3
25607	5
25608	5
25609	5
25624	19
25628	3
25635	19
25645	3
25660	19
25670	3
25671	1
25675	19
25676	2
25680	19
25685	3
25690	19
25695	2
25800	4
25805	5
25810	5
25820	4
25825	5
25830	5
25907	3
25922	3
25929	3
26011	1
26020	2
26025	1

HCPCS	ASC
26030	2
26034	2
26040	4
26045	3
26055	2
26060	2
26070	2
26075	4
26080	4
26100	2
26105	1
26110	1
26115	2
26116	2
26117	3
26121	4
26123	4
26125	4
26130	3
26135	4
26140	2
26145	3
26160	3
26170	3
26180	3
26185	4
26200	2
26205	3
26210	2
26215	3
26230	54
26235	3
26236	3
26250	3
26255	3
26260	3
26261	3
26262	2
26320	2
26350	1
26352	4
26356	4
26357	4
26358	4
26370	4
26372	4
26373	3
26390	4
26392	3
26410	3
26412	3

HCPCS	ASC
26415	4
26416	3
26418	4
26420	4
26426	3
26428	3
26432	3
26433	3
26434	3
26437	3
26440	3
26442	3
26445	3
26449	3
26450	3
26455	3
26460	3
26471	2
26474	2
26476	1
26477	1
26478	1
26479	1
26480	3
26483	3
26485	2
26489	3
26490	3
26492	3
26494	3
26496	3
26497	3
26498	4
26499	3
26500	4
26502	4
26508	3
26510	3
26516	1
26517	3
26518	3
26520	3
26525	3
26530	3
26531	7
26535	5
26536	5
26540	4
26541	7
26542	4
26545	4

HCPCS	ASC
26546	4
26548	4
26550	2
26555	3
26560	2
26561	3
26562	4
26565	5
26567	5
26568	3
26580	5
26587	5
26590	5
26591	3
26593	3
26596	2
26605	19
26607	19
26608	4
26615	4
26645	19
26650	2
26665	4
26675	19
26676	2
26685	3
26686	3
26705	19
26706	19
26715	4
26727	7
26735	4
26742	19
26746	5
26756	2
26765	4
26776	2
26785	2
26820	5
26841	4
26842	4
26843	3
26844	3
26850	4
26852	4
26860	3
26861	2
26862	4
26863	3
26910	3
26951	2

HCPCS	ASC
26952	4
26990	1
26991	1
27000	2
27001	3
27003	3
27033	3
27035	4
27040	1
27041	51
27047	2
27048	3
27049	3
27050	3
27052	3
27060	5
27062	5
27065	5
27066	5
27067	5
27080	2
27086	1
27087	3
27097	3
27098	3
27100	4
27105	4
27110	4
27111	4
27193	19
27194	2
27202	2
27230	19
27238	19
27246	19
27250	19
27252	2
27257	3
27265	19
27266	2
27275	2
27301	3
27305	2
27306	3
27307	3
27310	4
27323	1
27324	1
27325	2
27326	2
27327	2

HCPCS	ASC
27328	3
27329	4
27330	4
27331	4
27332	4
27333	4
27334	4
27335	4
27340	3
27345	4
27347	4
27350	4
27355	3
27356	4
27357	5
27358	5
27360	5
27372	7
27380	1
27381	3
27385	3
27386	3
27390	1
27391	2
27392	3
27393	2
27394	3
27395	3
27396	3
27397	3
27400	3
27403	4
27405	4
27407	4
27409	4
27418	3
27420	3
27422	7
27424	3
27425	7
27427	3
27428	4
27429	4
27430	4
27435	4
27437	4
27438	5
27441	5
27442	5
27443	5
27496	5

HCPCS	ASC
27497	3
27498	3
27499	3
27500	19
27501	19
27502	19
27503	19
27508	19
27509	3
27510	19
27516	19
27517	19
27520	19
27530	19
27532	19
27538	19
27550	19
27552	1
27560	19
27562	1
27566	2
27570	1
27594	3
27600	3
27601	3
27602	3
27603	2
27604	2
27605	1
27606	1
27607	2
27610	2
27612	3
27614	2
27615	3
27618	2
27619	3
27620	4
27625	4
27626	4
27630	3
27635	3
27637	3
27638	3
27640	2
27641	2
27647	3
27650	3
27652	3
27654	3
27656	2

HCPCS	ASC
27658	1
27659	2
27664	2
27665	2
27675	2
27676	3
27680	3
27681	2
27685	3
27686	3
27687	3
27690	4
27691	4
27692	3
27695	2
27696	2
27698	2
27700	5
27704	2
27705	2
27707	2
27709	2
27730	2
27732	2
27734	2
27740	2
27742	2
27745	3
27750	19
27752	19
27756	3
27758	4
27759	4
27760	19
27762	19
27766	3
27780	19
27781	19
27784	3
27786	19
27788	19
27792	3
27808	19
27810	19
27814	3
27816	19
27818	19
27822	3
27823	3
27824	19
27825	19

HCPCS	ASC
27826	3
27827	3
27828	4
27829	2
27830	19
27831	19
27832	2
27840	19
27842	1
27846	3
27848	3
27860	1
27870	4
27871	4
27884	3
27889	3
27892	3
27893	3
27894	3
28002	3
28003	3
28005	3
28008	3
28011	3
28020	2
28022	2
28024	2
28035	4
28043	2
28045	3
28046	3
28050	2
28052	2
28054	2
28055	4
28060	2
28062	3
28070	3
28072	3
28080	3
28086	2
28088	2
28090	3
28092	3
28100	2
28102	3
28103	3
28104	2
28106	3
28107	3
28108	2

HCPCS	ASC
28110	3
28111	3
28112	3
28113	3
28114	3
28116	3
28118	4
28119	4
28120	7
28122	3
28126	3
28130	3
28140	3
28150	3
28153	3
28160	3
28171	3
28173	3
28175	3
28192	2
28193	51
28200	3
28202	3
28208	3
28210	3
28222	1
28225	1
28226	1
28234	2
28238	3
28240	2
28250	3
28260	3
28261	3
28262	4
28264	1
28270	3
28280	2
28285	3
28286	4
28288	3
28289	3
28290	2
28292	2
28293	3
28294	3
28296	3
28297	3
28298	3
28299	5
28300	2

HCPCS	ASC
28302	2
28304	2
28305	3
28306	4
28307	4
28308	2
28309	4
28310	3
28312	3
28313	2
28315	4
28320	4
28322	4
28340	4
28341	4
28344	4
28345	4
28400	19
28405	19
28406	2
28415	3
28420	4
28435	19
28436	2
28445	3
28456	2
28465	3
28476	2
28485	4
28496	2
28505	3
28525	3
28531	3
28545	1
28546	2
28555	2
28575	19
28576	3
28585	3
28605	19
28606	2
28615	3
28635	1
28636	3
28645	3
28665	1
28666	3
28675	3
28705	4
28715	4
28725	4

HCPCS	ASC
28730	4
28735	4
28737	5
28740	4
28750	4
28755	4
28760	4
28810	2
28820	2
28825	2
29800	3
29804	3
29805	3
29806	3
29807	3
29819	3
29820	3
29821	3
29822	3
29823	3
29824	5
29825	3
29826	3
29827	5
29830	3
29834	3
29835	3
29836	3
29837	3
29838	3
29840	3
29843	3
29844	3
29845	3
29846	3
29847	3
29848	9
29850	4
29851	4
29855	4
29856	4
29860	4
29861	4
29862	9
29863	4
29870	3
29871	3
29873	3
29874	3
29875	4
29876	4

HCPCS	ASC
29877	4
29879	3
29880	4
29881	4
29882	3
29883	3
29884	3
29885	3
29886	3
29887	3
29888	3
29889	3
29891	3
29892	3
29893	55
29894	3
29895	3
29897	3
29898	3
29899	3
29900	3
29901	3
29902	3
30115	2
30117	3
30118	3
30120	1
30125	2
30130	3
30140	2
30150	3
30160	4
30220	53
30310	1
30320	2
30400	4
30410	5
30420	5
30430	3
30435	5
30450	7
30460	7
30462	9
30465	9
30520	4
30540	5
30545	5
30560	27
30580	4
30600	4
30620	7

HCPCS	ASC
30630	7
30801	1
30802	1
30903	14
30905	14
30906	14
30915	2
30920	3
30930	4
31020	2
31030	3
31032	4
31050	2
31051	4
31070	2
31075	4
31080	4
31081	4
31084	4
31085	4
31086	4
31087	4
31090	5
31200	2
31201	5
31205	3
31233	15
31235	1
31237	2
31238	1
31239	4
31240	2
31254	3
31255	5
31256	3
31267	3
31276	3
31287	3
31288	3
31300	5
31320	2
31400	2
31420	2
31510	2
31511	15
31512	2
31513	15
31515	1
31525	1
31526	2
31527	1

HCPCS	ASC
31528	2
31529	2
31530	2
31531	3
31535	2
31536	3
31540	3
31541	4
31545	4
31546	4
31560	5
31561	5
31570	2
31571	2
31576	2
31577	33
31578	2
31580	5
31582	5
31588	5
31590	5
31595	2
31603	1
31611	3
31612	1
31613	2
31614	2
31615	1
31620	1
31622	1
31623	2
31624	2
31625	2
31628	2
31629	2
31630	2
31631	2
31635	2
31636	2
31637	1
31638	2
31640	2
31641	2
31643	2
31645	1
31646	1
31656	1
31717	33
31720	11
31730	33
31750	5

HCPCS	ASC
31755	2
31820	1
31825	2
31830	2
32000	32
32400	1
32405	1
32420	32
33010	32
33011	32
33212	3
33213	3
33222	2
33223	2
33233	2
35188	4
35207	4
35875	9
35876	9
36260	3
36261	2
36262	1
36475	9
36476	9
36478	9
36479	9
36555	1
36556	1
36557	2
36558	2
36560	3
36561	3
36563	3
36565	3
36566	3
36568	1
36569	1
36570	3
36571	3
36575	2
36576	2
36578	2
36580	1
36581	2
36582	3
36583	3
36584	1
36585	3
36589	1
36590	1
36640	1

HCPCS	ASC
36800	3
36810	3
36815	3
36818	3
36819	3
36820	3
36821	3
36825	4
36830	4
36831	9
36832	4
36833	4
36834	3
36835	4
36860	22
36861	3
36870	9
37500	3
37607	3
37609	2
37650	2
37700	2
37718	3
37722	3
37735	3
37760	3
37780	3
37785	3
37790	3
38300	1
38305	2
38308	2
38500	2
38505	34
38510	2
38520	2
38525	2
38530	2
38542	2
38550	3
38555	4
38570	9
38571	9
38572	9
38740	2
38745	4
38760	2
40500	2
40510	2
40520	2
40525	2

HCPCS	ASC
40527	2
40530	2
40650	53
40652	53
40654	53
40700	7
40701	7
40720	7
40761	3
40801	2
40814	2
40816	2
40818	27
40819	1
40831	1
40840	2
40842	3
40843	3
40844	5
40845	5
41005	27
41006	1
41007	1
41008	1
41009	27
41010	1
41015	27
41016	1
41017	1
41018	1
41112	2
41113	2
41114	2
41116	1
41120	5
41250	27
41251	27
41252	2
41500	1
41510	1
41520	2
41800	16
41827	2
42000	27
42107	2
42120	4
42140	2
42145	5
42180	27
42182	2
42200	5

HCPCS	ASC
42205	5
42210	5
42215	7
42220	5
42226	5
42235	5
42260	4
42300	1
42305	2
42310	27
42320	27
42340	2
42405	2
42408	3
42409	3
42410	3
42415	7
42420	7
42425	7
42440	3
42450	2
42500	3
42505	4
42507	3
42508	4
42509	4
42510	4
42600	1
42665	7
42700	27
42720	1
42725	2
42802	1
42804	1
42806	2
42808	2
42810	3
42815	5
42820	3
42821	5
42825	4
42826	4
42830	4
42831	4
42835	4
42836	4
42860	3
42870	3
42890	7
42892	7
42900	1

HCPCS	ASC
42950	2
42955	2
42960	14
42962	2
42972	3
43200	1
43201	1
43202	1
43204	1
43205	1
43215	1
43216	1
43217	1
43219	1
43220	1
43226	1
43227	2
43228	2
43231	2
43232	2
43234	1
43235	1
43236	2
43237	2
43238	2
43239	2
43240	2
43241	2
43242	2
43243	2
43244	2
43245	2
43246	2
43247	2
43248	2
43249	2
43250	2
43251	2
43255	2
43256	3
43257	3
43258	3
43259	3
43260	2
43261	2
43262	2
43263	2
43264	2
43265	2
43267	2
43268	2

HCPCS	ASC
43269	2
43271	2
43272	2
43450	1
43453	1
43456	43
43458	43
43600	1
43653	9
43750	2
43760	26
43761	1
43870	1
44100	1
44312	1
44340	3
44360	2
44361	2
44363	2
44364	2
44365	2
44366	2
44369	2
44370	9
44372	2
44373	2
44376	2
44377	2
44378	2
44379	9
44380	1
44382	1
44383	9
44385	1
44386	1
44388	1
44389	1
44390	1
44391	1
44392	1
44393	1
44394	1
44397	1
45000	40
45005	2
45020	2
45100	1
45108	2
45150	2
45160	2
45170	2

HCPCS	ASC
45190	9
45305	1
45307	1
45308	1
45309	1
45315	1
45317	1
45320	1
45321	1
45327	1
45331	38
45332	38
45333	1
45334	1
45335	38
45337	38
45338	1
45339	1
45340	1
45341	1
45342	1
45345	1
45355	1
45378	2
45379	2
45380	2
45381	2
45382	2
45383	2
45384	2
45385	2
45386	2
45387	1
45391	2
45392	2
45500	2
45505	2
45560	2
45900	40
45905	1
45910	1
45915	40
45990	40
46020	3
46030	40
46040	3
46045	2
46050	40
46060	2
46080	3
46200	2

HCPCS	ASC
46210	2
46211	2
46220	1
46230	1
46250	3
46255	3
46257	3
46258	3
46260	3
46261	4
46262	4
46270	3
46275	3
46280	4
46285	1
46288	4
46608	1
46610	1
46611	1
46612	1
46615	2
46700	3
46706	1
46750	3
46753	3
46754	2
46760	2
46761	3
46762	7
46917	1
46922	1
46924	1
46937	2
46938	2
46946	1
46947	7
47000	1
47510	2
47511	56
47525	1
47530	1
47552	2
47553	3
47554	3
47555	3
47556	56
47560	3
47561	3
47630	3
48102	1
49080	32

HCPCS	ASC
49081	32
49180	1
49250	4
49320	3
49321	4
49322	4
49402	2
49419	1
49420	1
49421	1
49422	1
49426	2
49495	4
49496	4
49500	4
49501	9
49505	4
49507	9
49520	7
49521	9
49525	4
49540	2
49550	5
49553	9
49555	5
49557	9
49560	4
49561	9
49565	4
49566	9
49568	7
49570	4
49572	9
49580	4
49582	9
49585	4
49587	9
49590	3
49600	4
49650	4
49651	7
50200	1
50390	1
50392	1
50393	1
50395	1
50396	23
50398	1
50551	1
50553	1
50555	1

HCPCS	ASC
50557	1
50561	1
50688	1
50947	9
50948	9
50951	1
50953	1
50955	1
50957	1
50961	1
50970	1
50972	1
50974	1
50976	1
50980	1
51010	1
51020	4
51030	4
51040	4
51045	49
51050	4
51065	4
51080	1
51500	4
51520	4
51710	1
51715	3
51726	31
51772	23
51785	12
51880	1
51992	5
52000	1
52001	49
52005	2
52007	2
52010	49
52204	2
52214	2
52224	2
52234	2
52235	3
52240	3
52250	4
52260	2
52270	2
52275	2
52276	3
52277	2
52281	2
52282	9

HCPCS	ASC
52283	2
52285	2
52290	2
52300	2
52301	3
52305	2
52310	49
52315	2
52317	1
52318	2
52320	5
52325	4
52327	2
52330	2
52332	2
52334	3
52341	3
52342	3
52343	3
52344	3
52345	3
52346	3
52351	3
52352	4
52353	4
52354	4
52355	4
52400	3
52402	3
52450	3
52500	3
52510	3
52601	4
52606	1
52612	2
52614	1
52620	1
52630	2
52640	2
52647	9
52648	9
52700	2
53000	1
53010	1
53020	1
53040	2
53080	3
53200	1
53210	5
53215	5
53220	2

HCPCS	ASC
53230	2
53235	3
53240	2
53250	2
53260	2
53265	2
53270	2
53275	2
53400	3
53405	2
53410	2
53420	3
53425	2
53430	2
53431	2
53440	2
53442	1
53444	2
53445	1
53446	1
53447	1
53449	1
53450	1
53460	1
53502	2
53505	2
53510	2
53515	2
53520	2
53605	2
53665	1
54000	2
54001	2
54015	4
54057	1
54060	1
54065	1
54100	1
54105	1
54110	2
54111	2
54112	2
54115	1
54120	2
54150	1
54160	2
54161	2
54162	2
54163	2
54164	2
54205	4

HCPCS	ASC
54220	23
54300	3
54304	3
54308	3
54312	3
54316	3
54318	3
54322	3
54324	3
54326	3
54328	3
54340	3
54344	3
54348	3
54352	3
54360	3
54380	3
54385	3
54400	3
54401	3
54405	3
54406	3
54408	3
54410	3
54415	3
54416	3
54420	4
54435	4
54440	4
54450	31
54500	1
54505	1
54512	2
54520	3
54522	3
54530	4
54550	4
54600	4
54620	3
54640	4
54660	2
54670	3
54680	3
54690	9
54700	2
54800	21
54830	3
54840	4
54860	3
54861	4
54865	1

HCPCS	ASC
54900	4
54901	4
55040	3
55041	5
55060	4
55100	1
55110	2
55120	2
55150	1
55175	1
55180	2
55200	2
55250	2
55400	1
55500	3
55520	4
55530	4
55535	4
55540	5
55550	9
55680	1
55700	44
55705	44
55720	1
55725	2
55873	9
55875	9
56440	2
56441	1
56442	1
56515	3
56620	5
56625	7
56700	1
56740	3
56800	3
56810	5
57000	1
57010	2
57020	50
57023	1
57065	1
57105	2
57130	2
57135	2
57155	50
57180	29
57200	1
57210	2
57220	3
57230	3

HCPCS	ASC
57240	5
57250	5
57260	5
57265	7
57267	7
57268	3
57288	5
57289	5
57291	5
57300	3
57400	2
57410	2
57415	2
57513	2
57520	2
57522	2
57530	3
57550	3
57556	5
57558	3
57700	1
57720	3
58120	2
58145	5
58346	2
58350	3
58353	7
58545	9
58546	9
58550	9
58555	1
58558	3
58559	2
58560	3
58561	3
58562	3
58563	9
58565	9
58660	5
58661	5
58662	5
58670	3
58671	3
58672	5
58673	5
58800	3
58820	3
58900	3
58970	36
58974	36
58976	36

HCPCS	ASC
59160	3
59320	1
59812	5
59820	5
59821	5
59840	5
59841	5
59870	5
59871	5
60000	1
60200	2
60280	4
60281	4
61020	30
61026	30
61050	30
61055	30
61070	30
61215	3
61790	3
61791	45
61795	39
61885	2
61886	3
61888	1
62194	1
62225	1
62230	2
62263	1
62264	1
62268	30
62269	1
62270	25
62272	25
62273	1
62280	1
62281	1
62282	1
62287	9
62294	30
62310	1
62311	1
62318	1
62319	1
62350	2
62355	2
62360	2
62361	2
62362	2
62365	2
63600	2

HCPCS	ASC
63610	1
63650	2
63660	1
63685	2
63688	1
63744	3
63746	2
64410	1
64415	25
64417	25
64420	25
64421	1
64430	25
64470	1
64472	1
64475	1
64476	1
64479	1
64480	1
64483	1
64484	1
64510	1
64517	25
64520	1
64530	1
64553	1
64561	3
64573	1
64575	1
64577	1
64580	1
64581	3
64585	1
64590	2
64595	1
64600	1
64605	1
64610	1
64620	1
64622	1
64623	1
64626	1
64627	1
64630	45
64680	47
64681	2
64702	1
64704	1
64708	2
64712	2
64713	2

HCPCS	ASC
64714	2
64716	3
64718	2
64719	2
64721	2
64722	1
64726	1
64727	1
64732	2
64734	2
64736	2
64738	2
64740	2
64742	2
64744	2
64746	2
64771	2
64772	2
64774	2
64776	3
64778	2
64782	3
64783	2
64784	3
64786	3
64787	2
64788	3
64790	3
64792	3
64795	2
64802	2
64821	4
64831	4
64832	1
64834	2
64835	3
64836	3
64837	1
64840	2
64856	2
64857	2
64858	2
64859	1
64861	3
64862	3
64864	3
64865	4
64870	4
64872	2
64874	3
64876	3

HCPCS	ASC
64885	2
64886	2
64890	2
64891	2
64892	2
64893	2
64895	3
64896	3
64897	3
64898	3
64901	2
64902	2
64905	2
64907	1
65091	3
65093	3
65101	3
65103	3
65105	4
65110	5
65112	7
65114	7
65130	3
65135	2
65140	3
65150	2
65155	3
65175	1
65235	2
65260	3
65265	4
65270	2
65272	2
65275	4
65280	4
65285	4
65290	3
65400	1
65410	2
65420	2
65426	5
65710	7
65730	7
65750	7
65755	7
65770	7
65772	4
65775	4
65780	5
65781	5
65782	5

HCPCS	ASC
65800	1
65805	1
65810	3
65815	2
65820	1
65850	4
65865	1
65870	4
65875	4
65880	4
65900	5
65920	7
65930	5
66020	1
66030	1
66130	7
66150	4
66155	4
66160	2
66165	4
66170	4
66172	4
66180	5
66185	2
66220	3
66225	4
66250	2
66500	1
66505	1
66600	3
66605	3
66625	46
66630	3
66635	3
66680	3
66682	2
66700	2
66710	2
66711	2
66720	2
66740	2
66821	41
66825	4
66830	46
66840	4
66850	7
66852	4
66920	4
66930	5
66940	5
66982	8

HCPCS	ASC
66983	8
66984	8
66985	6
66986	6
67005	4
67010	4
67015	1
67025	1
67027	4
67030	1
67031	41
67036	4
67038	5
67039	7
67040	7
67107	5
67108	7
67112	7
67115	2
67120	2
67121	2
67141	35
67218	5
67227	1
67250	3
67255	3
67311	3
67312	4
67314	4
67316	4
67318	4
67320	4
67331	4
67332	4
67334	4
67335	4
67340	4
67343	7
67346	1
67400	3
67405	4
67412	5
67413	5
67415	1
67420	5
67430	5
67440	5
67445	5
67450	5
67550	4
67560	2

HCPCS	ASC
67570	4
67715	1
67808	2
67830	2
67835	2
67880	3
67882	3
67900	4
67901	5
67902	5
67903	4
67904	4
67906	5
67908	4
67909	4
67911	3
67912	3
67914	3
67916	4
67917	4
67921	3
67923	4
67924	4
67935	2
67950	2
67961	3
67966	3
67971	3
67973	3
67974	3
67975	3
68115	2
68130	2
68320	4
68325	4
68326	4
68328	4
68330	4
68335	4
68340	4
68360	2
68362	2
68371	2
68500	3
68505	3
68510	1
68520	3
68525	1
68540	3
68550	3
68700	2

HCPCS	ASC
68720	4
68745	4
68750	4
68770	4
68810	24
68811	2
68815	2
69110	1
69120	2
69140	2
69145	2
69150	53
69205	1
69300	3
69310	3
69320	7
69421	3
69436	3
69440	3
69450	1
69501	7
69502	7
69505	7
69511	7
69530	7
69550	5
69552	7
69601	7
69602	7
69603	7
69604	7
69605	7
69620	2
69631	5
69632	5
69633	5
69635	7
69636	7
69637	7
69641	7
69642	7
69643	7
69644	7
69645	7
69646	7
69650	7
69660	5
69661	5
69662	5
69666	4
69667	4

HCPCS	ASC
69670	3
69676	3
69700	3
69711	1
69714	9
69715	9
69717	9
69718	9
69720	5
69740	5
69745	5
69801	5
69802	7
69805	7
69806	7
69820	5
69840	5
69905	7
69910	7
69915	7
69930	7
G0105	2
G0121	2
G0260	1
G0392	9
G0393	9